

**Marathon Sensors Inc.  
VersaPro Oxygen Controller  
Installation and Operation Handbook**



***Marathon  
Sensors Inc.***

COPYRIGHT © 2004  
MARATHON SENSORS INC

## Marathon Sensors Inc.

---

Part # F200066

Revision 1.03 April 14, 2004  
Revision 1.04 September 30, 2004  
Revision 1.05 October 15, 2004  
Revision 1.06 December 15, 2004  
Revision 1.07 May 5, 2005

COPYRIGHT © 2005  
MARATHON SENSORS INC.  
3100 East Kemper Road, Cincinnati, Ohio 45241  
1-800-547-1055 (513) 772-1000 FAX: (513) 326-7090  
[www.marathonsensors.com](http://www.marathonsensors.com)

All trademarks used in this publication are duly marked and the sole property of their respective owners. No attempt at trademark or copyright infringement is intended or implied.

Marathon Sensors makes no warranties express or implied beyond the written warranty presented at initial purchase. Marathon Sensors Inc. is not responsible for any product, process, damage or injury incurred while using this equipment. Marathon Sensors makes no representations or warranties with respect to the contents hereof and specifically disclaims any warranties of merchantability or fitness for any particular application or purpose.

**Table of Contents**

**SAFETY AND ENVIRONMENT INFORMATION ..... 1**

    SERVICE AND REPAIR ..... 1

**INSTALLATION SAFETY REQUIREMENTS..... 1**

    SAFETY SYMBOL..... 1

    PERSONNEL..... 1

    ENCLOSURE OF LIVE PARTS ..... 2

    LIVE SENSORS ..... 2

    WIRING ..... 2

    POWER ISOLATION ..... 3

    EARTH LEAKAGE CURRENT ..... 3

    OVER CURRENT PROTECTION..... 3

    VOLTAGE RATING ..... 4

    CONDUCTIVE POLLUTION ..... 4

    OVER-TEMPERATURE PROTECTION..... 4

    GROUNDING OF THE TEMPERATURE SENSOR SHIELD ..... 5

    INSTALLATION REQUIREMENTS FOR EMC..... 5

    ROUTING OF WIRES ..... 5

**VERSAPRO FEATURES..... 6**

**INSTALLATION ..... 7**

    MOUNTING..... 8

**PROCESS CONTROL OPTIONS ..... 9**

**CONTROL MODES..... 9**

    TIME PROPORTIONING (TP)..... 9

    TIME PROPORTIONING WITH COMPLEMENT (TC)..... 9

    TIME PROPORTIONING DUAL (TD)..... 10

    DIRECT CURRENT OUTPUT..... 10

**ALARMS ..... 10**

    PROCESS ALARMS ..... 12

*OFF* ..... 12

*Full Scale HI*..... 12

*Full Scale LO*..... 12

*Deviation Band*..... 13

*Deviation High* ..... 13

*Deviation Low*..... 13

*Output High*..... 13

*Output Low*..... 13

*Fault* ..... 13

*Probe* ..... 13

    ALARM ACTION ..... 14

    ALARM DELAY TIMES..... 14

    DIAGNOSTIC ALARMS ..... 14

**FRONT PANEL OPERATION ..... 15**

    REMOTE KEY ..... 16

    SETPT KEY ..... 16

# Marathon Sensors Inc.

---

SETUP KEY .....	17
DUAL KEY FUNCTIONS .....	29
<i>Starting Probe Tests</i> .....	29
<i>Factory Test Mode</i> .....	29
<b>PROBE IMPEDANCE TEST .....</b>	<b>30</b>
WHY MEASURE SENSOR IMPEDANCE? .....	31
<b>PROBE VERIFICATION .....</b>	<b>32</b>
<b>TUNING.....</b>	<b>35</b>
WHAT IS TUNING? .....	35
<b>SCALING ANALOG INPUTS.....</b>	<b>38</b>
<i>Linear A example</i> .....	38
KEYBOARD FUNCTION DURING INPUT SLOPE.....	38
<b>SCALING ANALOG OUTPUTS .....</b>	<b>38</b>
<b>CALIBRATION .....</b>	<b>39</b>
CALIBRATION DISPLAYS AND KEYBOARD OPERATION .....	40
<i>Adjustment Sensitivity</i> .....	41
PREPARING FOR INPUT CALIBRATION.....	41
CALIBRATION OF THE THERMOCOUPLE INPUT.....	41
CALIBRATION OF THE PROBE MILLIVOLT INPUT .....	42
CALIBRATION OF THE ANALOG OUTPUT CHANNELS .....	43
<b>PROCESS CALCULATIONS .....</b>	<b>44</b>
OXYGEN PROCESS CONTROL.....	44
<b>DIGITAL COMMUNICATIONS.....</b>	<b>45</b>
<b>TECHNICAL SPECIFICATION.....</b>	<b>51</b>
ENVIRONMENTAL RATINGS .....	51
EQUIPMENT RATINGS .....	51
GENERAL .....	51
ELECTRICAL SAFETY (PENDING APPROVAL) .....	52
ELECTROMAGNETIC COMPATIBILITY (PENDING APPROVAL) .....	53

## Safety and Environment Information

**Please read this section carefully before installing the controller**

This instrument is intended for industrial applications used in conjunction with Marathon Sensors zirconia oxygen sensors and standard thermocouple types. It is assumed that any installation meets either CE standards for industrial safety or NEC standard wiring practices. Failure to observe these standards or the installation instructions in this manual may degrade the safety or electrical noise protection provided by this instrument. It is the installer's responsibility to ensure the safety and electrical noise compatibility of any installation.

### Service and repair

This controller has user replaceable fuses but no other user serviceable parts. Contact your Marathon Sensors Service (800-547-1055) for repair.

*Caution:* Charged capacitors

Before removing an instrument from its case, disconnect the supply and wait at least two minutes to allow capacitors to discharge. Failure to observe this precaution will expose capacitors that may be charged with hazardous voltages. In any case, avoid touching the exposed electronics of an instrument when withdrawing it from the case.

### Electrostatic Discharge (ESD) Precautions

When the controller is removed from its case, some of the exposed electronic components are vulnerable to damage by electrostatic discharge. Anyone who is not probably ground using an ESD wrist strap or in contact with a ground while handling the controller may damage exposed electronic components.

## Installation Safety Requirements

### Safety Symbol

Various symbols are used on the instrument, they have the following meaning:



The functional earth connection is required for safety ground add to ground RFI filters.

### Personnel

Installation must be carried out by qualified personnel.

### **Enclosure of live parts**

To prevent hands or metal tools touching parts that may be electrically live, the controller should be installed in an enclosure. The contacts on the rear of the instrument case or finger save but it is still possible for loose wiring, or metal objects to come in contact with live terminal connections. It is recommended that power be removed from the instrument connections before they are disconnected. However, instrument's power connector can be removed with power applied. Care should be taken that the connector does not come in contact with any grounded object.

### **Live sensors**

The dc inputs, dc logic, and dc outputs are all electrically isolated from chassis ground. If the temperature sensor is connected directly to an electrical heating element then the inputs will also be live. The controller is designed to operate under these conditions. However you must ensure that this will not damage other equipment connected to these inputs and that service personnel do not touch connections to these terminals while they are live. With a live sensor, all cables, connectors and switches for connecting the sensor and non-isolated inputs and outputs must be mains rated.

### **Wiring**

It is important to connect the controller in accordance with the wiring data given in this handbook. Take particular care not to connect AC supplies to the low voltage sensor input or other low level inputs and outputs. Only use copper conductors for connections (except thermocouple inputs) and ensure that the wiring for installations comply with all local wiring regulations. For example, in the UK, use the latest version of the wiring regulations, BS7671. In the USA use NEC Class 1 wiring methods. See Figure 1 for a schematic diagram of the instrument wiring.

Figure 1 Typical Wiring Diagram

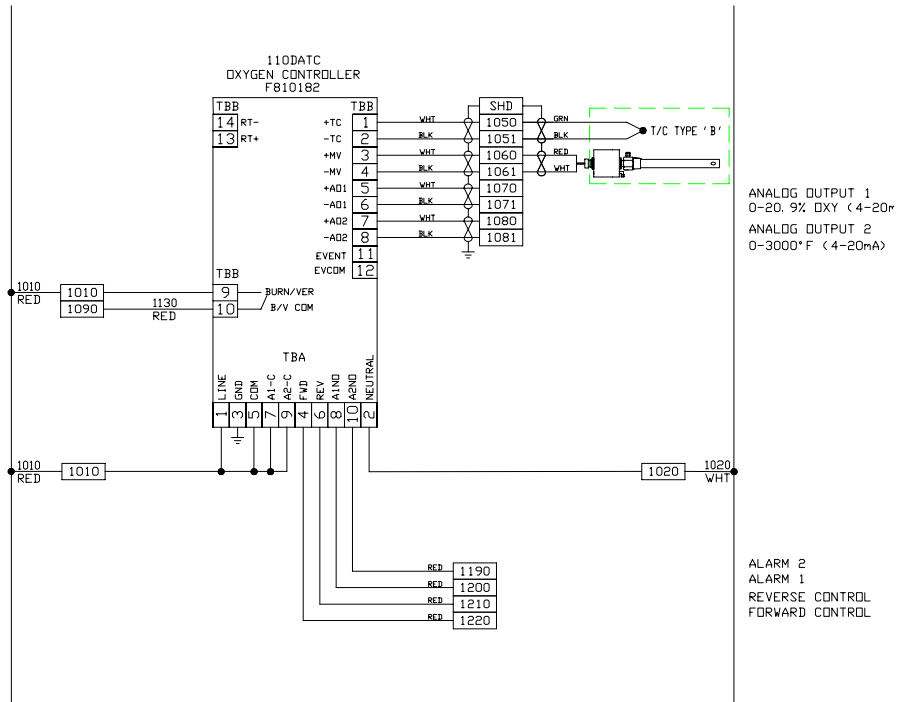

**Power Isolation**

The installation must include a power isolating switch or circuit breaker. This device should be in close proximity to the control actuator, and within easy reach of the operator. There is no means of disconnecting power from the instrument other than removing the connectors from the rear of the instrument. It is recommended that additional power disconnects are provided in the installation to remove power from these connectors as well.

**Earth leakage current**

Due to RFI Filtering there is an earth leakage current of less than 0.5mA. This may affect the design of an installation of multiple controllers protected by Residual Current Device, (RCD) or Ground Fault Detector, (GFD) type circuit breakers.

**Over Current protection**

The instrument has an internal 3.15 Amp fuse (P/N MFU-3.15PCTT) for instrument power and 1 Amp fuses (P/N MFU-1.0PCTT) for the control contacts and alarms. It is recommended that additional protection against excess currents be used for loads exceeding this rating. Fusing and interposing relays should be added to the control circuit if high current or large inductive loads are used.

### **Voltage rating**

The maximum continuous voltage applied between any of the following terminals must not exceed 250VAC:

- line or neutral to any other connection;
- relay output to logic, dc or sensor connections;
- any connection to ground.

The controller should not be wired to a three phase supply with an unearthed star connection. Under fault conditions in this supply could rise above 264VAC with respect to ground and the product would not be safe.

Voltage transients across the power supply connections, and between the power supply and ground, must not exceed 2.5kV. Where occasional voltage transients over 2.5kV are expected or measured, the power installation to both the instrument supply and load circuits should include a transient limiting device.

These units will typically include gas discharge tubes, metal oxide varistors, and constant voltage transformers help suppress voltage transients on the supply line due to lightning strikes or inductive load switching. Devices are available in a range of energy ratings and should be selected to suit conditions at the installation.

### **Conductive pollution**

Electrically conductive pollution must be excluded from the cabinet in which the controller is mounted. For example, carbon dust is a form of electrically conductive pollution. To secure a suitable atmosphere in conditions of conductive pollution, fit an air filter to the air intake of the cabinet. Where condensation is likely, for example at low temperatures, include a thermostatically controlled heater in the cabinet.

### **Over-temperature protection**

When designing any control system it is essential to consider what will happen if any part of the system should fail. In temperature control applications the primary danger is that the heating will remain constantly on. Apart from scrapping the product, this could damage any process machinery being controlled or even cause a fire.

Reasons why the heating might remain constantly on include:

- the temperature sensor becoming detached from the process;
- thermocouple wiring becoming a short circuit;
- the controller failing with its heating output constantly on;

- an external valve or contactor sticking in the heating condition;
- the controller setpoint set too high.

Where damage or injury is possible, we recommend fitting a separate over-temperature protection unit. Factory Mutual requires that any over temperature device use an independent temperature sensor, which will isolate the heating circuit.

Please note that the alarm relays within the controller will not give protection under all failure conditions. This instrument is not suited for over temperature protection and should not be used as a safety device.

### **Grounding of the temperature sensor shield**

In some installations it is common practice to replace the temperature sensor while the controller is still powered up. Under these conditions, as additional protection against electric shock, we recommend that the shield of the temperature sensor be grounded at one end of the wire. Do not rely on grounding through the framework of the machine.

### **Installation requirements for EMC**

To ensure compliance with European EMC directives certain installation precautions are necessary as follows:

- When using relay outputs it may be necessary to fit a filter suitable for suppressing the emissions. The filter requirements will depend on the type of load. For typical applications such as Schaffner FN321 or FN612 line filters or equivalents.
- If the unit is used in table top equipment which is plugged into a standard power socket, it is likely that compliance to the commercial and light industrial emissions standard is required. In this case, to meet the conducted emissions requirement, a suitable mains filter should be installed. Recommended filters would be Schaffner types FN321 and FN612 or equivalents.

### **Routing of wires**

To minimize the pick-up of electrical noise, the wiring for low voltage dc and particularly the sensor input should be routed away from high-current power cables. Where it is impractical to do this, use shielded cables with the shield grounded at one end.

## **VersaPro Features**

The VersaPro is a single loop process controller / monitor has the following capabilities:

- Two channel 24 bit Sigma-Delta ADC for thermocouple, probe millivolt, with cold junction compensation.
- tacts.
- Internal relay for oxygen sensor verification.
- Internal relay for sensor impedance testing.
- Two (2) 4-20 milliamp outputs for control or chart recorder.
- Sixteen character LCD with two four digit LED segment displays.
- Two (2) Form A control contacts.
- Two (2) Form A alarm contacts.
- PID control modes.
- EEPROM stores setup and calibration values.

## Installation

The VersaPro instrument is designed for up to 1/8" panel mounting in a DIN standard opening of 3.62" square (adapter panels available by special order). Required rear clearance is 7" to allow for wiring.

As with all solid state equipment, the controller should be located away from excessive heat, humidity, and vibration. Since the unit uses LED and LCD display devices, it should also be located so that direct sunlight will not interfere with the display's visibility. The instrument requires 120/240 VAC 50/60 Hz and should not be on the same circuit with other noise-producing equipment such as induction machines, large electrical motors, etc. Signal wiring must be run separate from control wiring. It is suggested that signal wiring at the rear terminals of the instrument be routed in one direction (up or down) while the AC power wires are routed in the opposite direction.

The following figure shows the rear terminals locations on the rear of the VersaPro.

Figure 2 VersaPro Rear Panel

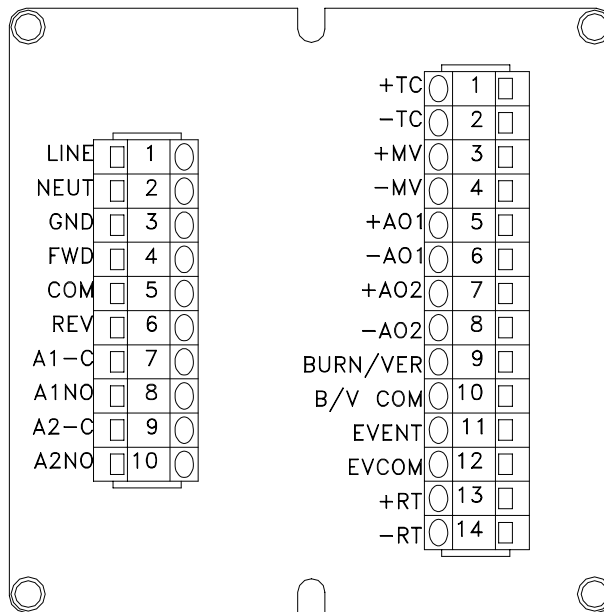

**Mounting**

To mount the instrument in a control panel, a hole must be cut 3.62" square in the necessary location on the panel. The following procedure should be followed to mount the VersaPro in the panel.

- 1) Insert the unit into previously cut out 3.62" square hole in panel.
- 2) While supporting unit, insert one clamping bracket into the groove on the bottom of unit, and then install the 6-32 set screw.
- 3) Repeat step 2 for the top of the unit.
- 4) With a HEX KEY wrench, alternately tighten the screw on either side of instrument to a torque of six in.-lbs. Insure rigidity of mounting. **DO NOT OVER TIGHTEN.** This can warp the instrument enclosure and make removal difficult.

To remove the instrument from the panel, reverse the above procedures.

## Process Control Options

The Versapro is configured to perform as a single loop PID controller for a specific process. This instrument is setup as an oxygen controller.

**Table 1 Instrument Control Options**

Function	Description
Oxygen	Uses the millivolt and temperature signals from a zirconia sensor to calculate oxygen concentrations and control to an oxygen set point.

## Control Modes

The VersaPro controller provides:

- Time Proportional Single (TP)
- Time Proportional Dual (TD)
- Time Proportional Complement (TC)

The instrument controls with two control contacts or direct 4-20mA output from two analog output channels. The control function can be set to direct acting or reverse acting. The monitor option is the only option shown when the instrument has been configured as a monitor only.

### Time Proportioning (TP)

Time proportioning adjusts the duty cycle of the control device to maintain control. This is usually done with solenoid valves controlling the flow of a trim gas or addition to the process. The control loop percent output is the ON time percentage of the value relative to total cycle time. The cycle time is the ON time plus OFF time.

For example if the control loop percent output is 34% and the cycle time is 10 seconds, then the ON time would be 3.4 seconds and the OFF time would be 6.6 seconds. The selection of the proper cycle time is a trade off between excess wear and tear on the solenoid valve with short cycle times and rough (pulsing) flow of the control material with long cycle times. Only the first control contact is used in this mode.

### Time Proportioning with Complement (TC)

This mode is identical to the time proportioning mode except that both control outputs are used. The second control output is the complement of the first. That is when the first output is ON then the second is OFF and vice versa. This mode is used with single action motorized valves that open quickly when a voltage is applied to one terminal and close quickly when voltage is applied to the other terminal.

**Time Proportioning Dual (TD)**

This mode is used when there are two processes to control that have complementary effects; like gas and air. The time proportioning dual mode uses two control outputs; one for gas and one for air. There is never a time when both outputs are on simultaneously. The control loop computes a percent output from -100 to +100%. When positive, the proportioning action applies to the forward output (gas). When negative the proportioning action applies to the reverse (air) output.

**Direct Current Output**

The analog outputs can be configured to control the process or provide 4 to 20mA signals proportional to selectable process values. The Analog Output Offset and Range can be set to correspond to the process range.

If a chart recorder is used, it should have input specifications of 0 - 5 VDC or 4 - 20 mA. If the recorder only responds to a DC voltage input, it will be necessary to add a 250 ohm dropping resistor across its input terminals and scale the analog output as 0 – 20mA.

The ideal location of the recorder is adjacent to the instrument but it may be located remotely if the connecting wires are properly shielded. For best results, the chart recorder input(s) should be isolated from ground. When ever possible, it is preferable to use a 4-20mA signal since it is less susceptible to noise.

**Alarms**

The instrument has two types of alarms, process alarms and diagnostic alarms. If an alarm has been selected and conditions are such that the alarm becomes active, the instrument will display this condition on the center LCD display. The alarms a numbered as Alarm 1 and Alarm 2. The various displays for active alarm conditions would be displayed as shown below. N indicates the position of the alarm number, 1 or 2.

ALARM DISPLAY	CONDITION	ACTION
PROCESS HIGH	Process alarm, contact assignable	Full Scale High, Contact automatically resets unless latched.
PROCESS LOW	Process alarm,	Full Scale Low,

## Marathon Sensors Inc.

---

ALARM DISPLAY	CONDITION	ACTION
	contact assignable	Contact automatically resets unless latched.
PROCESS HIGH OR LOW	Process alarm, contact assignable	Deviation Band, Contact automatically resets unless latched.
PROCESS HIGH	Process alarm, contact assignable	Deviation High, Contact automatically resets unless latched.
PROCESS LOW	Process alarm, contact assignable	Deviation Low, Contact automatically resets unless latched.
PROCESS HIGH	Process alarm, contact assignable	Power Output High, Contact automatically resets unless latched.
PROCESS LOW	Process alarm, contact assignable	Power Output Low, Contact automatically resets unless latched.
PROBE IMPEDANCE	Probe alarm, contact assignable	Probe Impedance High, Contact automatically resets unless latched.
VERIFICATION	Probe alarm, contact assignable	Probe Verification out of tolerance, Contact automatically resets unless latched.
LLLL	Display only	Displays process value within display range or exponent setting
HHHH	Display only	Displays process value within display range or exponent setting
FLASH CSUM	Fault alarm, contact assignable	Reset instrument power. Return to Marathon if error does not clear.
EEPROM CSUM	Fault alarm, contact assignable	Reset instrument power. Return to Marathon if error does not clear.
KEYBOARD	Fault alarm, contact assignable	Reset instrument power. Do not push any keys while instrument is powered

## Marathon Sensors Inc.

---

ALARM DISPLAY	CONDITION	ACTION
		on. Return to Marathon if error does not clear.
FLASH ERASE	Fault alarm, contact assignable	Programming error, Reset instrument power, attempt reload.
FLASH / EE SIZE	Fault alarm, contact assignable	Programming error, Reset instrument power, attempt reload.
ADC FAULT	Fault alarm, contact assignable	Reset instrument power. Return to Marathon if error does not clear.
TEMP OPEN	Fault alarm, contact assignable	Check thermocouple for open condition or loose connection.
MV OPEN	Fault alarm, contact assignable	Check probe millivolt signal for open condition or loose connection. This signal can only be tested if the probe temperature is above 1300°F and exposed to process gas.

### Process Alarms

The process alarms can be setup to activate either or both of the two alarm contacts provide on the VersaPro. Nine user selectable modes are available.

#### *OFF*

Disables the alarm function and the alarm contacts.

#### *Full Scale HI*

An alarm is generated any time the process value goes above the Full Scale HI alarm value. This alarm is reset if the process falls below the alarm value or acknowledgement from the front panel or through the event input (if configured).

#### *Full Scale LO*

An alarm is generated any time the process value drops below the Full Scale LO alarm value. The alarm will arm once the process is measured above the alarm

value. This alarm is reset with an acknowledgement from the front panel or through the event input (if configured).

### *Deviation Band*

An alarm is generated any time the process value goes above or below the band alarm setting. The alarm setting is  $\pm$  value of the band. For example, if a value of 10 is entered as the alarm value, an alarm is generated if the process goes 10 units above or 10 units below the set point. Units are the process units such percent or degrees. This alarm will not arm until the process is in-band of the set point.

### *Deviation High*

An alarm is generated any time the process value goes above the band alarm setting. The alarm setting is number of units allowed above set point. Units are the process units such percent or degrees. This alarm will not arm until the process is in-band of the set point.

### *Deviation Low*

An alarm is generated any time the process value goes below the band alarm setting. The alarm setting is number of units allowed below the set point. Units are the process units such percent oxygen or degrees. This alarm will not arm until the process is in-band of the set point.

### *Output High*

An alarm is generated any time the control percent output exceeds the alarm value. The alarm setting is maximum percent output allowed.

### *Output Low*

An alarm is generated any time the control percent output drops below the alarm value. The alarm setting is minimum percent output allowed.

### *Fault*

An alarm is generated any time an open input occurs on either the T/C or MV inputs. Both inputs are pull up to a maximum value if no input is connected or if the input fails in an open circuit mode. An open T/C input fault is ignored for the Linear configuration. The center display will indicate which of these conditions has caused the alarm. The alarm process will also become active if any of the listed hardware faults occur. The center display will indicate which of these conditions has caused the alarm.

### *Probe*

An alarm is generated any time the probe exceeds the maximum probe impedance setting, or the verification test tolerance. All of the probe values and limits are configured in the Probe Menu. The center display will indicate which of these conditions has caused the alarm.

## Alarm Action

Each alarm can be configured to operate in several different modes. Each alarm can be configured as a reverse (normally closed) contact. This mode is usually used for failsafe alarms that will open during an alarm condition, fault, or power failure. Each alarm can also be configured as a direct (normally open) contact that closes when an alarm condition occurs. In both cases the alarm will automatically clear if the alarm condition is resolved.

Each alarm can also be configured for either reverse or direct latched conditions. In this mode the alarm contact will remain active until an acknowledgement is received through the event port or by pressing the ENTER key.

## Alarm Delay Times

Each alarm can have delay ON, delay OFF, or both delays applied. Delays can be applied in increments of a second, up to a maximum of 250 seconds. ON delays are helpful if a known upset in the process can be ignored. This avoids nuisance alarms but still maintains an active alarm if the alarm condition persists following the delay. OFF delays will hold the alarm contact active for a determined period of time once the alarm condition has cleared. This can be helpful as an interlock to other process functions that may have to recover following an alarm condition.

## Diagnostic Alarms

A diagnostic alarm is shown on the instrument's center display when a fault is detected in the internal hardware during power up. These alarms included:

FLASH CSUM	A fault has been detected in the Flash memory.
EEPROM CSUM	A fault has been detected in the EEPROM.
KEYBOARD	A key is stuck or was held down during power up.
FLASH ERASE	This error may occur during instrument programming. The Flash memory may be faulty. Retry programming, make sure the communications link to the instrument is working properly.
FLASH / EE SIZE	This error may occur during instrument programming. The Flash memory may be faulty. Retry programming, make sure the communications link to the instrument is working properly.
ADC FAULT	The analog / digital converter has failed to initialize or failed self calibration.

If either alarm contact is configured for a fault this alarm will engage if any of the above faults occur. The LCD display will indicate the fault condition.

The front panel display will show 0000 if the process value is below the display resolution, or HHHH if the process value is above the display resolution. It may be necessary to adjust the oxygen exponent and/or the oxygen decimal point settings if these symbols occur.

## Front Panel Operation

The instrument has a display/keyboard assembly. This assembly has a 2 x 4 keyboard group, two groups of four LED seven segment displays (upper and lower), and a single line sixteen character LCD display.

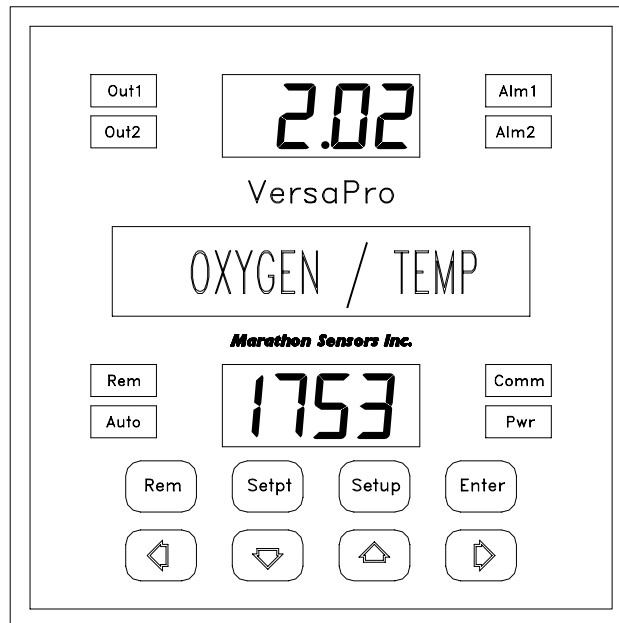

**Figure 3 VersaPro Display**

The LEDs to either side of the LED segment arrays light when the corresponding function is active.

- COMM flashes when the instrument is properly interrogated over the RS485 port.
- PWR is hard wired to the instrument 5VDC supply
- AUTO is lit when the instrument is controlling to a local set point
- REM is lit when the instrument is controlling to a remote set point

The upper display indicates the process value or the Setup Menu Heading when the SETUP key has been pressed.

The center display will indicate what scaling is being used for the oxygen measurement. In figure 2 the instrument is indicating that % oxygen is being measured. This measurement range can be changed to indicate parts per million (ppm) or other measurement ranges based on the oxygen exponent setting in the Setup Calc(ulation) menu. The exponent setting has a range of 0 to E-31. Other possible displays could be; Oxygen E-12, Oxygen E-20, etc.

The center display also shows the parameter name in Setup mode or flashes a fault or alarm message if any are active.

The lower display shows the instrument set point if the controller is in automatic or remote mode. The display will switch to control output level when the instrument is changed to manual. The monitor option will display the probe temperature by default. The lower display can be configured to display other parameters based on the instrument option.

### **Remote Key**

Pressing the REM key causes the VersaPro to cycle between Manual, Automatic, or Remote. When switching from Manual to Automatic, the control output remains at the last output value Manual mode. This output is eventually changed by the PID calculation based on the error between the set point and the process level.

When the controller is set to Automatic mode the “Auto” LED lights and the lower display indicates the local process setpoint (default).

When the controller is set to Remote mode the “Rem” LED lights and the VersaPro will accept a remote setpoint from a master on the host serial interface if configured for serial communications. The lower display indicates the process setpoint. The default value is zero.

When the controller is set to Manual mode neither the “Rem” and “Auto” LED’s are lit and the lower display indicates the power output of the controller. This value can be manually increased or decreased in 1% steps by pressing the UP or DOWN arrow keys. Pressing the RIGHT or LEFT arrow keys changes the output in 10% steps. The output will remain at the last control level if the instrument is switched from manual mode to automatic until a new value is calculated to the PID routine.

### **SETPT Key**

The SETPT key provides access to the instrument process set point. When the key is pressed the center display will show “SET POINT”. The set point value in the lower display can then be manually changed by moving the flashing digit cursor with the RIGHT or LEFT arrow keys and increasing or decreasing the selected digit with the UP or DOWN arrow keys. You can exit the set point function by pressing the

## Marathon Sensors Inc.

---

SETPT key again. Any changes that are made to the set point are then displayed in the lower window if the instrument is set up of Automatic control.

The following table outlines the options available under the Set Point key.

**Table 2 Setpoint Ranges**

Parameter Name	Range	Description
SET POINT	0 – 999.9 O2	Units for oxygen are based on display resolution and exponent setting.

### Setup Key

The instrument can be placed in setup mode by pressing and holding the SETUP key for 5 seconds. The upper display initially shows the first setup menu while the center and lower displays are blank. At this level you can select different menus by pressing the RIGHT or LEFT arrow keys. The upper display will change accordingly.

You can enter a menu by pressing the ENTER key when the desired menu heading is being displayed. Pressing the arrow keys can change menu parameters. Value changes can be saved or the next parameter can be selected by pressing the ENTER key. The menu parameters will continue to cycle through the display as long as the ENTER key is pressed. A new menu can be select only when the menu heading is displayed. You can exit from the Setup mode by pressing the SETUP key at any time.

The following tables outline the Setup menus available in the VersaPro Controller and Monitor when the operator presses the SETUP key.

**Table 3 Setup Menus**

Setup Menu Heading	Description
<i>Ctrl</i>	Control functions and PID
<i>InPt</i>	Thermocouple type and Millivolt setup
<i>Calc</i>	Oxygen exponent setting
<i>Prob</i>	Probe tests and verification parameters
<i>Out</i>	Analog output selection and parameters
<i>Alr</i>	Alarm contact configurations
<i>Info</i>	General information displays
<i>Cal</i>	Input / Output calibration

## Marathon Sensors Inc.

---

You have to press the SETUP key for five seconds to activate the setup mode. Initially when the setup mode is activated, the LCD display will show the first menu heading, the upper and lower LED displays are blank. Page to the next Menu heading by pressing the RIGHT or LEFT arrow keys. The menu headings will continue to wrap around as the RIGHT or LEFT arrow keys are pressed. Pressing the SETUP key at any point while in the Setup Menus will return the display to the normal process display. See figure 3.

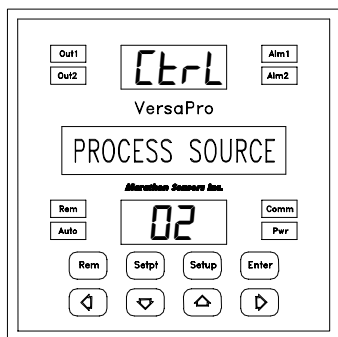

The displayed menu is selected by pressing the ENTER key. The first parameter name in the selected menu list will appear in the center display. The upper LED group continues to display the menu name, the center display shows the parameter name, and the lower LED group shows the parameter value. A flashing cursor in the lower LED display indicates which digit can change if the parameter value is numeric.

The UP or DOWN arrows increase or decrease the digit value. The RIGHT or LEFT arrow keys move the cursor to the right or left digit. No wrap-around is provided for the cursor.

If the parameter has a table of choices such as thermocouple types, the various selections can be displayed by pressing the UP or DOWN arrows. No digit flashes in parameter displays that have a choice selection. In either case, the selection is set when the ENTER key is pressed and the display advances to the next parameter.

In the example shown above, the selected menu is Control (Ctrl), the selected parameter is Control Type, and the displayed parameter value is Time Dual (td). This is one of several control types that are available. Different control selections can be made by pressing the UP or DOWN arrow keys.

Pressing the SETUP key at any time escapes from the menu display and returns to the normal process display. You can only select another menu heading when the display is at a menu heading.

The following figures and tables outline the menu options and parameters under the Setup key.

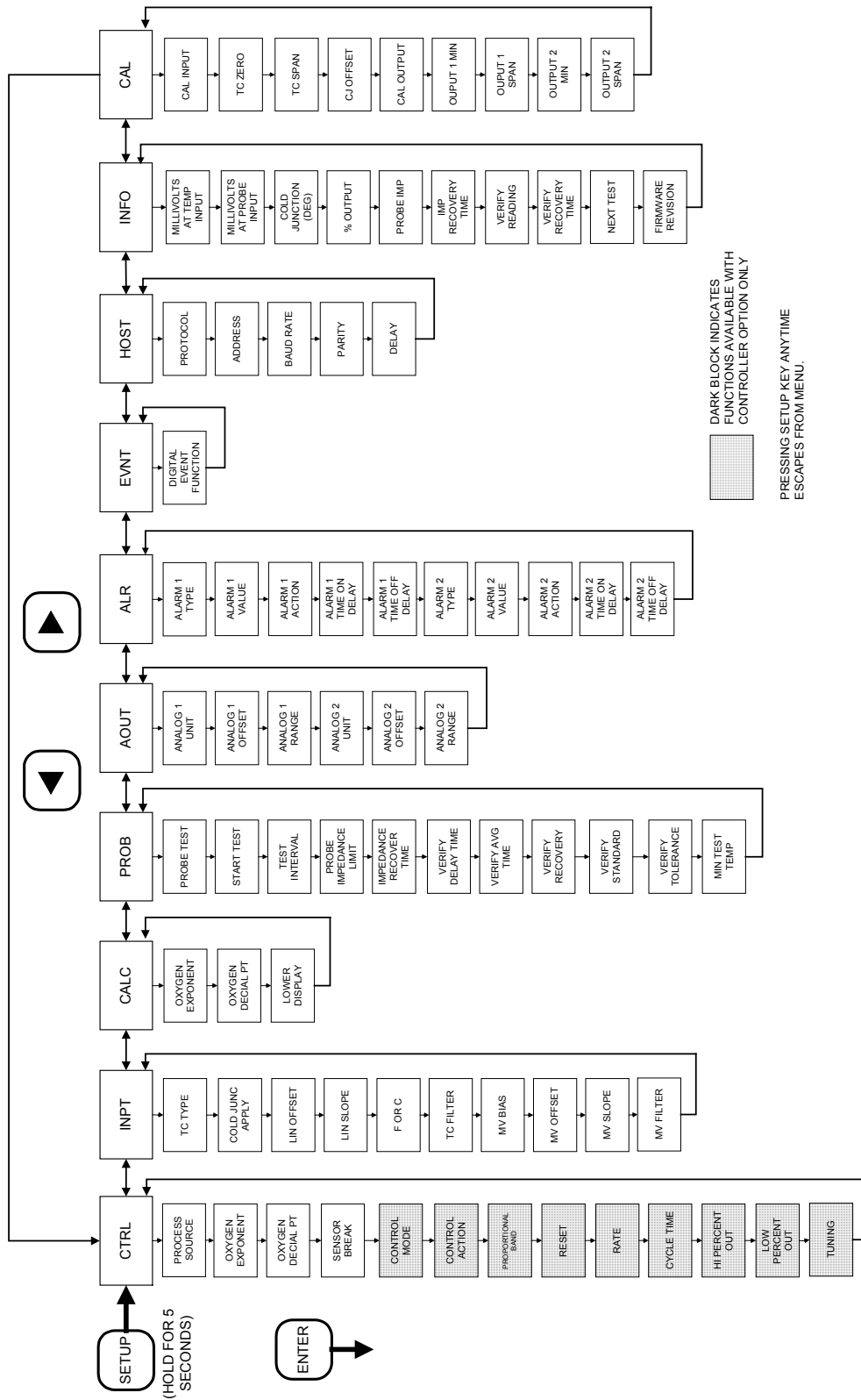

Figure 4 Setup Menu Tree

## Marathon Sensors Inc.

---

**Table 4 Control Menu (Ctrl)**

Parameter Name	Units or Options	Range	Description
PROCESS SOURCE	O2, INPUT A, INPUT B	Display range: 0.000 to 9999 for oxygen 0 to 100 or EU for Input A 0 to 2000 or EU for Input B	Control type only available on instrument's specific configuration. This selection controls what other parameters will be available.
CONTROL MODE	TP, TC, TD		See Control Modes if configured as a controller.
CONTROL ACTION	DIR/REV		Direct or Reverse control action
PROPORTIONAL BAND	Process Value	0 – 9999	Proportional Band value in displayed process units for PID control or Deadband in ON/OFF control
RESET	Repeats / min	00.00 – 99.99	Integral control value, no effect in ON/OFF settings
RATE	Repeats / min	00.00 – 9.99	Derivative control value, no effect in ON/OFF settings
CYCLE TIME	SECONDS	0 – 255	Proportional time period (TP, TC, TD)
HI PERCENT OUT	MAXIMUM OUTPUT	0 – 100	Sets max. forward control. Output
LOW PERCENT OUT	MINIMUM OUTPUT	-100 to 100	Sets min. reverse control output
SENSOR OPEN		0% OUTPUT HOLD	0% OUTPUT sets the control output to 0 if a thermocouple break and/or an open mV input are detected. HOLD holds the output to the last averaged output prior to a break and/or open input.

**Table 5 Input Menu (Input)**

Parameter Name	Units or Options	Range	Description
TC TYPE	B, E, J, K, N, R, S, T		See Input calibration for thermocouple ranges. Linear mode allows for input scaling, see IN A OFFSET and IN A

## Marathon Sensors Inc.

---

Parameter Name	Units or Options	Range	Description
			SLOPE.
COLD JUNC APPLY	YES or NO		Applies the cold junction correction or not when a thermocouple type is selected. In LINEAR mode the cold junction is never applied. Default is NO.
IN A OFFSET	Only in Linear mode	-999 – 9999	Linear offset to scale Input A to Engineering Units when INPUT A is selected as the process source.
IN A SLOPE	Only in Linear mode	-999 – 999 -99.9 – 99.9 -9.99 – 9.99 -.999 - .999	Linear slope to scale Input A to Engineering Units when INPUT A is selected as the process source. This is the slope number in the linear calculation where: $EU = SLOPE(mV) + OFFSET$ See key
TEMP SCALE	F OR C		Sets temperature scale.
TC FILTER	SECONDS	0 – 999.9	Temperature filter time constant. Filters the temperature value with a moving average time window.
IN B OFFSET	Works only in mV Mode	-999 – 9999	Linear offset to scale Input B to Engineering Units when INPUT B is selected at the process source. This is the offset in used in the $SLOPE(mV) + OFFSET$ equation.
IN B SLOPE	Works only in mV Mode	-999 – 999 -99.9 – 99.9 -9.99 – 9.99 -.999 - .999	Linear slope to scale Input B to Engineering Units when INPUT B is selected as the process source. This is the slope number in the linear calculation where: $EU = SLOPE(mV) + OFFSET$
MV FILTER	SECONDS	0 – 999.9	Millivolt filter time constant. Filters the millivolt reading with a

**Marathon Sensors Inc.**

---

Parameter Name	Units or Options	Range	Description
			moving average time window

**Table 6 Calculation Menu (CALC)**

Parameter Name	Units or Options	Range	Description
OXYGEN EXPONENT	POWER OF TEN	0 – 31	2 = %, 6 = ppm, 9 = ppb Available in O2 only. The negative value of the exponent is assumed. (This parameter is also shown in control menu)
DISPLAY DECML PT	Decimal point	0-4	Sets decimal pt., available for O2, Input A and Input B. (This parameter is also shown in control menu)
LOWER DISPLAY	SETP, TENP, PO		Allows the operator to change the displayed value in lower LED display during REM and AUTO modes. Setpoint (SETP) is the default. MAN always displays percent output (PO). Oxygen Monitor always shows probe temperature (TENP). Millivolt monitor is blank.

**Table 7 Probe Setup Menu (PrOb)**

Parameter Name	Units or Options	Range	Description
PROBE TEST		NONE RES VER BOTH	No test (NONE), Impedance (RES), Verification (VER), or BOTH impedance and verification can be selected.
START TEST		YES/NO	If probe test interval is 0, then test only runs once. If probe test interval is set then test run continuously from start point and at each interval time. Test stops when changed back to NO.

## Marathon Sensors Inc.

---

Parameter Name	Units or Options	Range	Description
			Probe temp must be $\geq$ the minimum probe temperature setting.
TEST INTERVAL	HRS.TENTHS	0 – 99.9	Sets time interval between automatic probe tests, 0 disables automatic testing.
PROBE IMP LIMIT	KOHMS	10 – 100	Sets maximum impedance for Probe alarm
IMP RECVRY TIME	SECONDS	0 – 250	Sets maximum Probe recovery time, timer cut short if probe recovers faster. The Probe alarm is set if the probe signal does not recover while this timer is active.
VERIFY DELAY	SECONDS	0 – 999	Initial verification delay. O <sub>2</sub> function only. This delay allows time for the verification gas to flow to the tip of the probe.
VERIFY AVG TIME	SECONDS	0 – 999	Verification sampling time.
VERIFY RECOVERY	SECONDS	0 – 999	Recovery time for probe following verification test. The PROBE alarm is set if the probe signal does not recover before this timer expires.
VERIFY STANDARD	% OXYGEN	0 – 25.0	Percent of O <sub>2</sub> used as verification gas.
VERIFY TOLERANCE	% OXYGEN	0 – 25.0	Tolerance (O <sub>2</sub> %) for acceptable measurement. Specified in the same units as the displayed O <sub>2</sub> . O <sub>2</sub> function only. The PROBE alarm is set if the oxygen level measured during verification exceeds this tolerance.
MIN PROBE TEMP	F OR C	1100° – 2000° F 590° – 1090° C	Minimum temperature for probe impedance and verification tests.

**Table 8 Analog Output Menu (AOUT)**

Parameter Name	Units or Options	Range	Description
ANALOG 1 UNIT	O2, LIN, TENP, POUT, PO1, PO2, PROG	4 to 20mA output.	<p><b>O2</b> – retransmits Oxygen if oxygen is selected as process source.</p> <p><b>LIN</b> – scaled millivolt value of either input A or input B, depending on which one is selected as process source.</p> <p><b>TENP</b> – probe temperature when oxygen is selected as process source and a thermocouple type is selected.</p> <p><b>POUT</b> – Power output is available for the controller, allows for -100% to 100% for split actuators. PO1 or PO2 allow for just 0 – 100% output for either control contact.</p> <p><b>PROG</b> - allows the output to be controlled from the DACV1 memory location.</p>
ANALOG 1 OFFSET	Offset for selected process value or percent output.	<p>O2 = 0 to 9999</p> <p>LIN = -999 to 9999</p> <p>TEMP = -999 to 3000</p> <p>POUT = LOPO</p> <p>PROG = 0</p>	<p>This is the minimum value of the process associated with the 4mA output. The magnitude of this number is based on the display resolution.</p> <p>In POUT mode the offset is fixed to the LOPO value. When PROG is selected the offset is fixed at 0</p>
ANALOG 1 RANGE	Span scaling for selected process value or percent output.	<p>O2 = 0 to 9999</p> <p>LIN = -999 to 9999</p> <p>Temp = -999 to 3000</p> <p>POUT = HIPO</p>	<p>This is the maximum value of the process associated with the 20mA output. The magnitude of this number is based on the display resolution. When POUT is selected this value is fixed to the HIPO value. When PROG is selected</p>

**Marathon Sensors Inc.**

---

Parameter Name	Units or Options	Range	Description
		PROG = 4095	the range is fixed at 4095.
ANALOG 2 UNIT	O2, LIN, TENP, POUT, PO1, PO2, PROG		Same as Analog 1
ANALOG 2 OFFSET	Offset for selected process value or percent output.		Same as Analog 1
ANALOG 2 RANGE	Span scaling for selected process value or percent output.		Same as Analog 1

**Table 9 Alarm Menu (ALr)**

Parameter Name	Units or Options	Range	Description
ALARM 1 TYPE	OFF FSHI, FSLO DBAN DHI DLO OHI OLO FALT PROB		<p><b>OFF</b> disables alarm contact.</p> <p><b>FSHI - Full Scale HI</b>, active when process is above ALARM 1 VALUE.</p> <p><b>FSLO - Full Scale LO</b>, active when process is below ALARM 1 VALUE.</p> <p><b>DbAn – Deviation Band</b> available for the controller only, active when process is outside of symmetrical band around setpoint.</p> <p><b>DHI – Deviation High</b>, defines a process band above the process setpoint. The alarm is active if the process moves outside this band.</p> <p><b>DLO – Deviation Low</b>, defines a process band below the process setpoint. The alarm is active if the process moves outside this band.</p> <p><b>OHI – Output High</b>, this alarm sets the threshold for the maximum control output allowed which is set</p>

## Marathon Sensors Inc.

---

Parameter Name	Units or Options	Range	Description
			by ALARM 1 VALUE. <b>OLO – Output Low</b> , this alarm sets the threshold for the minimum control output allowed which is set by ALARM 1 VALUE. <b>Falt – Fault</b> , open inputs for mV, thermocouple or hardware fault. <b>Prob – Probe</b> , fault active if impedance or verification are out of range.
ALARM 1 VALUE			Trigger set point value
ALARM 1 ACTION	REV, LREV, DIR, LDIR		REV = Reverse (N.C.) can be acknowledged even if the condition still exists. LREV = Latched Reverse (N.C.) can not be acknowledged if the condition still exists. DIR = Direct (N.O.) can be acknowledged even if the condition still exists. LDIR = Latched Direct (N.C.) can not be acknowledged if the condition still exists.
ALRM 1 TM ON DLY	0 – 250 SECONDS		Delay ON time for ALARM1
ALRM 1 TMOFF DLY	0 – 250 SECONDS		Delay OFF time for ALARM1
ALARM 2 TYPE	Same as ALARM 1 TYPE	OFF	Same as ALARM 1 TYPE
ALARM 2 VALUE			Trigger set point value
ALARM 2 ACTION			Same as ALARM 1 ACTION
ALRM 2 TM ON DLY	0 – 250 SECONDS		Delay ON time for ALARM2
ALRM 2 TMOFF DLY	0 – 250 SECONDS		Delay OFF time for ALARM2

## Marathon Sensors Inc.

---

**Table 10 Event Menu (EUnT)**

Parameter Name	Units or Options	Range	Description
DIGITL EVNT FUNC	OFF, PROB, AUTO,REN, ACK, HOLd		PROB = Contact on/off starts probe tests (if configured) AUTO = Contact on/off switches to automatic control. (controller only) REN = Contact on/off switches to remote control (controller only) ACK = Contract on/off resets alarm (if not currently active) HOLd= Process control and analog outputs are frozen while event contact is closed.

**Table 11 Communication Menu (HOSL)**

Parameter Name	Units or Options	Range	Description
PROTOCOL	PROP OR BUSS		PROP is Marathon Sensors, Inc. protocol, BUSS is Modbus
ADDRESS	1 TO 15 (MSI) 1 TO 255 (MOD)		
BAUD RATE	NA,600,1200, 2400,4800,9600, 19.2K,38.4K		
PARITY	None/Even/Odd		
DELAY	NONE / 10		NONE = 0 Delay 10 = 10 ms delay

**Table 12 Info Menu (I nFO)**

Parameter Name	Units or Options	Range	Description
MILLIVOLT TEMP IN	MILLIVOLTS	-10-100	Displays direct mV of Temperature input
MILLIVOLT PROB IN	MILLIVOLTS	0-2000	Displays direct mV reading of probe input
COLD JUNCTION	DEG (F OR C)	0 – 60°C	Displays actual cold junction temperature
PERCENT OUTPUT	% Output	LOPO to HIPO	Displays actual % output

## Marathon Sensors Inc.

---

Parameter Name	Units or Options	Range	Description
PROB IMPEDANCE	Kohms	0 – 100	Displays last probe impedance value.
IMP RECVRY TIME	SECONDS	0 – 250	Displays last impedance recovery time.
VERIFY READING	% OXYGEN	0 – 025.0	Displays last verification reading. O2 configuration only.
NEXT TEST	Hours.tenths		Time to next probe test, shows 00.0 if test automatic test is disabled.
FIRMWARE REV	Version number		

**Table 13 Calibration Menu**

Parameter Name	Units or Options	Range	Description
CAL INPUT	NO / YES		Default to NO, must be changed to YES to enter input calibration routine.
TC ZERO			Changes calibration value for thermocouple zero
TC SPAN			Changes calibration value for thermocouple span
CJ OFFSET (CAL IN)		0 – 60° C 0 – 140° F	Sets the cold junction offset depending on the temperature range selected
CAL OUTPUT	NO / YES		Default to NO, must be changed to YES to enter output calibration routine.
OUTPUT 1 MIN (CAL OUTPUT)			Sets signal level for the minimum mA output.
OUTPUT 1 SPAN (CAL OUTPUT)			Sets signal level for the maximum mA output.
OUTPUT 2 MIN (CAL OUTPUT)			Sets signal level for the minimum mA output.
OUTPUT 2 SPAN (CAL OUTPUT)			Sets signal level for the maximum mA output.

Pressing the Setup key once at any point in the Setup menu will return the instrument to the normal process display.

## **Dual Key Functions**

The VersaPro has three dual key functions as defined below:

ENTER / RIGHT arrow	Initiates probe test sequence
ENTER / REM	Factory test Mode

### *Starting Probe Tests*

Pressing the ENTER / RIGHT arrow keys simultaneously will start the probe tests if a probe test function has been selected in the Probe Setup Menu, parameter Probe Test, and the probe temperature is above the minimum probe temperature parameter in the same menu.

If there is a value other than 0 entered in the Probe Test Interval parameter the probe test will be performed after the selected interval time has elapsed from the time the test was manually started. If the interval time is set to 0 then no additional tests will be performed until the next manual start. Starting the test through this dual key function is the same as if the Start Test parameter in the Probe menu had been changed from NO to YES.

### *Factory Test Mode*

This mode is used by factory personnel only. Return to operate mode by cycling power or sending the appropriate command word to the instrument.

## **Probe Impedance Test**

The probe impedance test is performed by measuring the open circuit voltage of the probe, applying a known shunt resistor across it and measuring the shunted voltage output. The value of the shunt resistor is 10kohm for oxygen sensors.

To run a probe impedance test it is necessary setup the probe testing parameter in the SETUP Probe Menu. Please refer to Probe parameters table for an explanation of these setup parameters. It is necessary to have the impedance (RES) test or both (BOTH) selected at the PROBE TEST parameter in order to run the impedance test. You may choose to accept the defaults for the other parameters in this menu or change them to suit your applications. It is necessary that the sensor be above the MIN PROBE TEMP parameter setting for this test to run. It is also necessary for the probe to be measuring a stable process gas during this test.

There are two ways to start this test. From the Probe Setup menu at the START TEST parameter, you can change this parameter from NO to YES and then press the ENTER key. The instrument will exit the Setup mode and display the test name and sequence number on the front display. The LCD display will indicate "IMPEDANCE TEST" while the lower LED display will show the test sequence number as listed in the following table.

It is also possible to start the test in the process display mode by pressing the ENTER and RIGHT ARROW keys at the same time. The test can be stopped by returning to the START TEST parameter and changing YES to NO and then pressing ENTER.

If the TEST INTEVAL parameter has a number other than 00.0 then the test will continue to run each time the test interval timer counts down to 0. This test interval can be stopped by setting the interval timer to 00.0.

The following table explains the various operations of the impedance test.

**Table 14 Probe Impedance Sequence**

Sequence #	Description
1	Inhibit process variable calculations. Freeze all process controls and outputs.
	Freeze alarms at last state except clear any previous probe test failure alarm.
	Store present probe millivolt reading
	Apply shunt resistor across probe
2	Wait for impedance test timer, fixed time of 30 seconds
	Compute impedance of probe and remove shunt resistor. Save measured impedance as PROBE IMPEDANCE in INFO menu.
	If impedance is greater than PROBE IMP LIMIT then set probe test failure alarm.
3	Wait for probe to recover to $\geq 99\%$ of original millivolts.
	Evaluate actual recovery time to IMP RECVRY TIME
	If recovery time is greater than IMP RECVRY TIME then set probe test failure alarm.
	Store recovery time (or max value ) as IMP RECVRY TIME in INFO menu
4	If verification is to be performed then go to step 1 of verification sequence
	Otherwise wait 30 seconds and resume normal operation of all instrument functions.

**Why Measure Sensor Impedance?**

It is important to track sensor impedance over a period of time to help determine the replacement schedule for the sensor. A high impedance ( $>50\text{ K}\Omega$ ) indicates that the electrode contact on the probe zirconia has deteriorate to a level that probably warrants replacement. High sensor impedance results in a lower signal output from the sensor and an eventual failure of the electrode connection on the process side of the zirconia ceramic. This deterioration is more of a factor in highly reducing atmospheres. In such applications, it may be necessary to check the impedance at least once a month. Under light reducing, annealing, or brazing operations, the impedance may not have to be check unless there is a question about the probe’s performance.

A typical impedance for a new probe is less than 1 K $\Omega$ . As the probe starts to age the impedance will increase. Past 20 KOHM the sensor should be monitored more closely. Above 50 K $\Omega$ , the sensor should be replaced. If it is necessary to replace the sensor, remove it carefully, following the instructions supplied with the sensor. Do not discard a sensor with a high impedance. It may be possible to rebuild the sensor if the ceramic parts are intact. Contact Marathon Sensors, Inc. for information on rebuilding your sensor.

An impedance test can only be performed if the probe temperature is at or above 1300°F with stable atmosphere present. The instrument freezes all control functions and process signals during the test.

A 10 $\Omega$  resistor is shunted across the sensor output. The sensor impedance is calculated as:

$$R_x = [(E_o/E_s)-1]*R_s$$

Where  $R_x$  = sensor impedance,  $E_o$  = sensor's open circuit voltage,  $E_s$  = shunted sensor's voltage, and  $R_s$  = shunt resistor. The units of  $R_x$  are the same as  $R_s$ .

### Probe Verification

Probe verification is performed by measuring the probe signal when a known calibration gas has been allowed to flood the sheath of the oxygen probe. A ¼" CPI compression fitting at the mounting hub of Marathon Sensors oxygen sensors is provided for the connection the verification gas. When a gas of known oxygen level is allowed to flow through this port, it floods the probe sheath and flows out and around the oxygen sensor. This method does not use the process as the basis for measurement nor does it have to assume that the process is stable, but the sensor does have to be above the MIN PROBE TEMP parameter found in the PROBE setup menu. This value is typically 1300°F or higher.

To run a probe verification test it is necessary setup the probe verification test parameters in the SETUP Probe Menu. Please refer to Probe parameters table for an explanation of these setup parameters. It is necessary to have the verification (VER) test or both (BOTH) selected at the PROBE TEST parameter in order to run the verification test. You may choose to accept the defaults for the other parameters in this menu or change them to suit your application. It is necessary that the sensor be above the MIN PROBE TEMP parameter setting for this test to run. It is not necessary for the probe to be measuring a stable process gas during this test.

There are two ways to start this test. From the Probe Setup menu at the START TEST parameter, you can change this parameter from NO to YES and then press the ENTER key. The instrument will exit the Setup mode and display the test name and sequence number on the front display. The LCD display will indicate "VERIFY

TEST” while the lower LED display will show the test sequence number as listed in the following Table.

It is also possible to start the test in the process display mode by pressing the ENTER and RIGHT ARROW keys at the same time. The test can be stopped by returning to the START TEST parameter and changing YES to NO and then pressing ENTER.

If the TEST INTEVAL parameter has a number other than 00.0 then the test will continue to run each time the test interval timer counts down to 0. This test interval can be stopped by setting the interval timer to 00.0.

Readings are averaged to eliminate variations in measurement due to initial flow conditions. There are three operator inputs for verification time periods;

- TEST INTERVAL is an interval timer that sets the time between automatic verifications in hours and tenths. The verification can be manually initiating by pressing and holding the Enter key and then the Left Arrow key. Setting the test interval time to zero disables automatic testing.
- VERIFY DELAY TIME is the initial stabilization period in seconds.
- VERIFY AVG TIME is the measurement averaging time period in seconds.
- VERIFY RECOVERY is the time period in seconds that allows the probe to recover and return to the process level.

Two values allow the operator to set the actual value of the verification gas and the allowed tolerance for the measured comparison.

- VERIFY STANDARD is the oxygen level of the gas standard in percent oxygen.
- VERIFY TOLERANCE is the measurement tolerance specified in percent oxygen.
- MIN PROBE TEMP is the minimum probe temperature that must be met to allow the test to proceed.

The following table outlines the actions the instrument takes at each sequence step.

**Table 15 Probe Verification Sequence**

Sequence #	Description
1	Inhibit process variable calculations. Freeze all process controls and outputs.
	Freeze alarms at last state except clear any previous probe test failure alarm.
	Close verification contact and wait the VERIFY DELAY time period.
2	Average oxygen readings from probe during the VERIFY AVE TIME period.
3	Release the verification contact and wait the VERIFY RECOVERY time period.
	Evaluate the averaged oxygen reading to the VERIFY STANDARD ± VERIFY TOLERANCE. Set alarm fault if comparison fails.
	Save averaged verification reading as VERIFY READING in INFO menu.
4	Resume normal operation of all instrument functions.

The equation for the verification sequence is the standard percent oxygen equation:

$$\%O_2 = \frac{20.95}{e^{(E/0.0215 \cdot T_k)}}$$

Where:

E = probe millivolts, T<sub>k</sub> = probe temperature in degrees Kelvin.

20.95 is the %O<sub>2</sub> in air.

## Tuning

Before attempting to tune the instrument make sure you understand the *Operation and Setup* part of the instrument.

### What is tuning?

Tuning the controller means that the control characteristics of the controller are matched to those of the process in order to obtain hold the process to setpoint. Good control means:

- Stable, ‘straight-line’ control of the process variable at setpoint without fluctuation
- No overshoot, or undershoot, of the process variable relative to setpoint
- Quick response to deviations from the setpoint caused by external disturbances, thereby rapidly restoring the process variable to the setpoint value.

Tuning involves calculating and setting the value of the parameters listed the following table. These parameters appear in the Control Setup menu.

**Table 16**

Parameter	Meaning or Function
Proportional band	The bandwidth, in display units, over which the output power is proportioned between minimum and maximum.
Integral time (Reset)	Determines the time taken by the controller to remove steady-state error signals.
Derivative time (Rate)	Determines how strongly the controller will react to the rate-of-change of the measured value.

The Versapro uses the Proportional Band as a representation of the Proportion section of PID, the Reset as a representation of the Integral section of PID, and the Rate as a representation of the Derivative section of PID. Thus by following a simple procedure, PID tuning can easily be implemented in any control situation. A suggested procedure is diagramed in the next figure.

All of the PID parameters may be altered by changing these parameters in the Setup / Ctrl menu. The following procedure assumes the initial PID values for a typical batch furnace. You may be able to start with a proportional band setting of 10 or less for a smaller box or temper furnace.

If, after following the procedure, the process continues to oscillate, it may be necessary to change the HIPO or LOPO parameters. Make sure that the control output is linear through the full range from LOPO to HIPO. In situations where the system is difficult to tune, it is most likely the output is not linear or there is too much lag time between the control command and measurable changes in the process. Test the system in manual mode to verify the output is linear.

A much higher proportional band may be necessary for extreme lag in the process response. In most cases, the derivative part of the control equation is not necessary. Generally, furnace control can be maintained using only the proportional band and the reset parameters.

Make sure you record all operating parameters and keep them in a secure place for later reference.

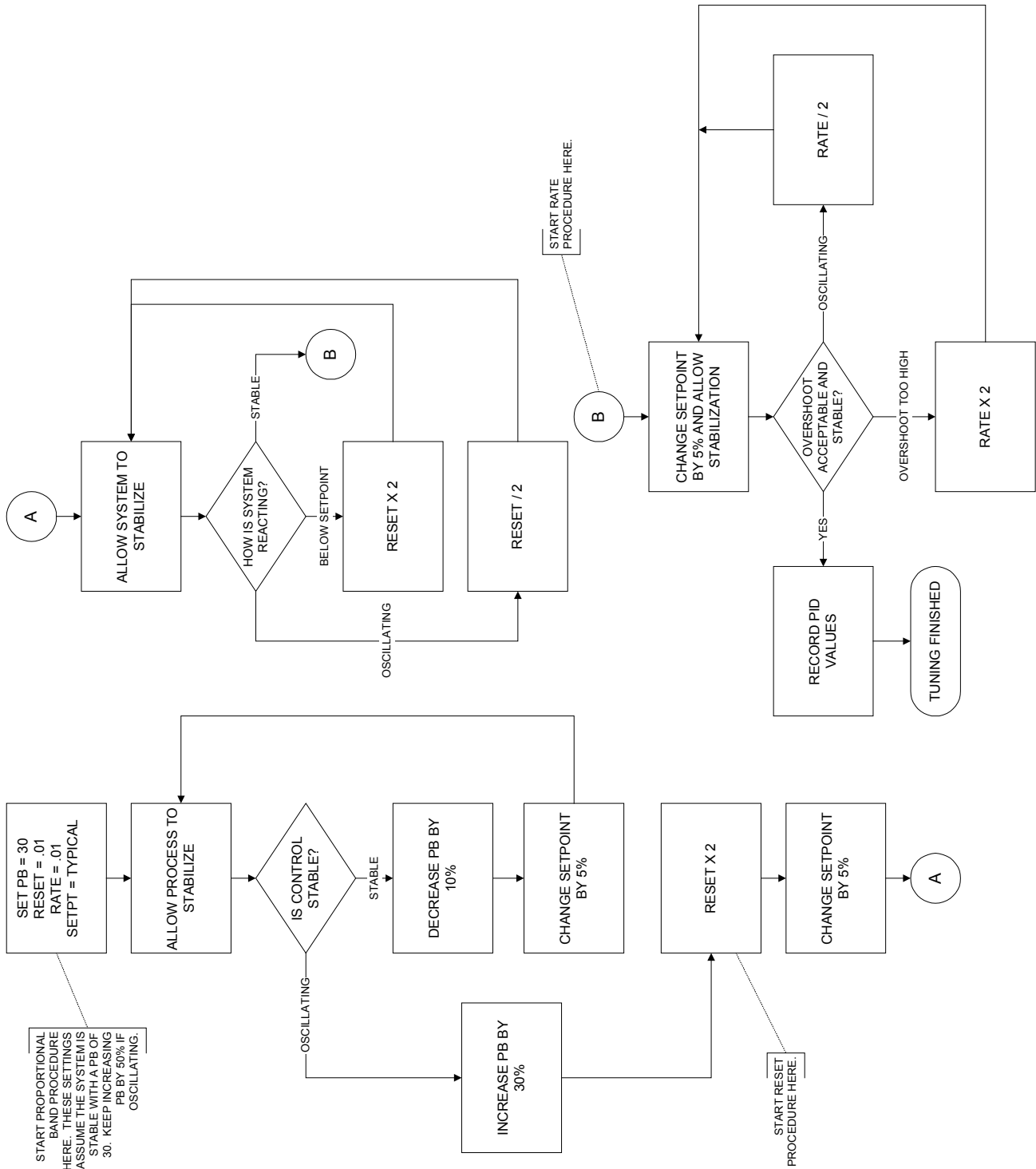

Figure 5 PID Tuning Procedure

## **Scaling Analog Inputs**

If either input is set to Linear mode the displayed value for that input can be scaled to desired engineering units. This is helpful if the measured linear value has to be scaled and re-transmitted on one of two analog output channels.

Using the equation  $y = mx + b$ , where

Y is the desired engineering unit to be displayed

X is the linear millivolt value

M is the Slope of the y/x relationship

B is the y intercept

### *Linear A example*

Let us use Input A as a linear input for a linear oxygen cell that outputs a 0mV to 53.2mV signal over a 0% to 100% oxygen range. Since both the signal output and the process minimum are both 0, the Input A offset will be 0. The slope can be calculated by dividing the maximum process value (100) by the maximum input level (53.2mV). This gives a slope value of 1.879. Since the slope parameter only has three digits, the actual number to be entered is 1.88. The decimal point has to be shifted twice to the left.

These scaling values will produce a process value of 100.0160% oxygen for a maximum sensor input of 53.2mV. The process display can be configured to display either 100 or 100.0. This process value can then be retransmitted to other control devices or a recorder. The control model of the Versapro will be able to control to a set point for the new process value.

### **Keyboard Function during Input Slope**

The three left digits in the slope display can be changed from 0 to 9. The most significant digit position allows you to shift the decimal point by pressing the LEFT arrow key. The decimal point will loop from first digit to the third digit as the LEFT arrow key is pressed. The RIGHT arrow key moves the display cursor back to the numbered digits.

## **Scaling Analog Outputs**

The analog outputs are scaled to simple offset and span values. For example if analog output 1 is to be scaled for a 0 to 100% oxygen value, the offset value would be 0 and the span value would be 100. This assumes that the process oxygen value is also scaled for percent oxygen where the oxygen exponent is set to 2.

For ppm values the analog output would be scaled to the display resolution of the process. For example, if the process display is 6.5 ppm, with a oxygen exponent of 6, the full scale display resolution would be any number between 000.0 and 999.9.

The analog output can be scaled to a reasonable range of 0 to 10, which would drive the 4 – 20mA output over a 0 to 10ppm range and the 6.5 ppm process value would result in an output of 14.4mA.

The same rules apply to analog output 2. The range of the offset and span numbers depends on the range of the process value that has been selected for either analog output.

Additional selections for Power Output and Program mode have fixed offset and span values. The power output offset and span values are fixed to the LOPO and HIPO values selected for the control outputs under the Setup Control menu.

The Program mode selection has a fixed offset of 0 and a fixed span of 4096. When this output mode is selected the analog output can only be changed by writing a value to either the DACV1 or DACV2 registers.

## Calibration

There are two analog inputs, a cold junction compensation sensor, and two analog outputs on the VersaPro. The input level is determined by which terminals are used for the input signal. There are two pairs of input terminals: TB-B 1, 2 for the thermocouple (T/C) input and TB-B 3, 4 for the probe millivolt input.

The 4 – 20mA analog outputs are at TB-B 5, 6 and TB-B 7, 8.

The following is a brief description of input/output and its specifications.

- |    |                |                 |                                             |
|----|----------------|-----------------|---------------------------------------------|
| a) | T/C Input      | Input range     | -10 to +70 millivolts $\pm$ 2 $\mu$ V       |
|    |                | TC burnout      | >full scale                                 |
| b) | Probe mV Input | Input range     | -50 to +2000 millivolts $\pm$ .1 mV, linear |
|    |                | Input impedance | 40 megohm                                   |
|    |                | Open input      | >full scale                                 |
| c) | Output 1       | Output range    | 0 to 20 milliamps                           |
|    |                | Max. Load       | 650 ohms                                    |
| d) | Output 2       | Output range    | 0 to 20 milliamps                           |
|    |                | Max. Load       | 650 ohms                                    |

### **Calibration Displays and Keyboard Operation**

When entering the Calibration Menu, the operator has to answer one of two questions depending on which input or output functions have to be calibrated. If the CALIBRATION IN prompt is answered with a YES, then the parameters related to the thermocouple input, millivolt input, and cold junction are displayed.

Pressing the Enter key at the first prompt skips the input calibration. A second prompt, CALIBRATION OUT is displayed. If this prompt is answered with a YES, then the parameters relate to the analog outputs are displayed.

In the Calibration Menu the displays and front panel keys take on special assignments. The process display shows the value of the input being calibrated with a flashing digit. This flashing digit indicates the relative sensitivity of the arrow keys, as described following the key descriptions. The upper LED display indicates the zero or the span value is being modified. The lower LED display indicates the calibration factor that is changed for each I/O channel. The LCD display indicates the name of the parameter to be adjusted.

It is very important that the display is indicating the proper I/O parameter before making an adjustment or the wrong value will be changed.

Once the particular calibration mode is selected, the process values are displayed in the upper LED group. The following keys perform the described functions:

<u>Key</u>	<u>Function</u>
LEFT ARROW	Increases the adjustment sensitivity by moving the blinking cursor to the most sensitive position (far left position). A further press of the key loops the adjustment to the least sensitive position (far right position).
RIGHT ARROW	Decreases the adjustment sensitivity by moving the blinking cursor to the least sensitive position (far right position). A further press of the key loops the adjustment to the most sensitive position (far left position).
UP ARROW	Increases the digit indicated by the blinking cursor.
DOWN ARROW	Decreases the digit indicated by the blinking cursor.
ENTER	Cycles to next input value or saves the calibration changes.
SETUP	Exits the calibration mode.

### *Adjustment Sensitivity*

The adjustment sensitivity works in the following manner. If the right most digit in the process display is flashing then each press of the up or down arrow key will change the displayed process value by a single calibration unit. If the left most digit is flashing then each press of the up or down arrow key will change the process value by a thousand calibration units. Likewise the middle digits will indicate sensitivities of a hundred and ten units respectively. The input value will usually change by an amount less than the calibration factor; however, by observation of the change, the sensitivity can be selected in order to allow the calibration factors to be adjusted more quickly. As the desired value is approached, less sensitive adjustments are required.

### **Preparing for Input Calibration**

Make sure you have the correct thermocouple type selected on the instrument if you see a significant difference between the thermocouple input and the displayed temperature on the instrument.

### **Calibration of the Thermocouple Input**

This calibration procedure assumes that a thermocouple type has been selected.

Calibration procedure:

1. Connect the input to be calibrated to a junction compensated calibrator (i.e. Biddle Instrument Co. Versa-Cal Calibrator) using the proper extension wire for the thermocouple type selected.
2. Activate the calibration mode by entering the SETUP menus, selecting the Calibration menu and changing Calibration IN - NO to YES.
3. Use the Enter key to select the TC ZERO mode.
4. Set the calibrator output to the recommended zero value in Table 17 for the thermocouple type selected.
5. Using the arrow keys, adjust the process value to equal the calibrator input.
6. Press the Enter key to select the TC SPAN mode.
7. Set the calibrator output to the recommended span value in the following table for the thermocouple type selected.
8. Using the arrow keys, adjust the process value to equal the calibrator output.

9. Repeat steps 3 through 8 by pressing the Enter key until no additional change is needed.

**Table 17 Thermocouple Calibration Values**

T/C type	Minimum Value °F (°C)	Maximum Value °F (°C)
B	800 (426)	3000 (1800)
E	-454 (-270)	1832 (1000)
J	32 (0)	1300 (900)
K	32 (0)	2300 (1200)
N	32 (0)	2300 (1200)
R	300 (150)	3000 (1800)
S	300 (150)	3000 (1800)
T	32 (0)	700 (350)

The usable ranges for the thermocouple types are shown in the following table . If it is desirable to have a higher accuracy over a specific operating range then the input should be calibrated over that range.

**Table 18 Usable Thermocouple Range (°F)**

T/C type	Minimum Value (°F)	Maximum Value (°F)
B	800	3270
E	-440	1830
J	-335	1400
K	-340	2505
N	-325	2395
R	300 *	3210
S	300 *	3210
T	-380	755

\* Due to the extreme non-linearity of low level signals, using type R and S below 300° F is not recommended.

**Calibration of the Probe Millivolt Input**

Calibration procedure:

1. Connect terminals TB-B 3, 4 to an isolated, stable voltage source calibrator.
2. Set the calibrator output to zero or short TB-B 3, 4 together with a short piece of wire.

3. Activate the calibration mode by entering the SETUP menus, selecting the Calibration menu and changing Calibration IN - NO to YES.
4. Use the Enter key to select the MV ZERO mode.
5. Set the calibrator output to a zero millivolt output.
6. Using the arrow keys, adjust the process value to equal the calibrator input.
7. Press the Enter key to select the MV SPAN mode.
8. Set the calibrator output to the required millivolt span (2000mV maximum). The display will not show the thousandth digit but only shows the lower digits for a higher adjustment resolution.
9. Using the arrow keys, adjust the process value to equal the calibrator output.
10. Repeat steps 4 through 9 by pressing the Enter key until no additional change is needed.

### Calibration of the Analog Output Channels

The same calibration procedure can be used for either output channel.

Calibration procedure:

1. Connect terminals TB-B 5, 6 (or 7, 8) to a multimeter such as a Fluke 77. Select the milliamp measurement range and verify that the test leads are plugged into the milliamp jack and common on the multimeter.
2. Activate the calibration mode by entering the SETUP menu, selecting the Calibration menu (**CAL**), press the ENTER key until CAL OUTPUT - nO is displayed.
3. Change the nO prompt to YES using the UP arrow key.
4. Press the ENTER key to select the OUTPUT 1 MIN mode. In OUTPUT 2 is required, continue pressing the ENTER key until OUT 2 MIN is displayed.
5. Using the UP or DOWN arrow keys, adjust the flashing digit value. Press the RIGHT or LEFT arrow keys to select the adjustment sensitivity. Adjust the displayed value until the multimeter indicates the desired minimum output. This is typically 4 mA but this level can be adjusted from 0mA to 20mA.
6. Press the ENTER key to select the OUTPUT 1 SPAN mode. If OUTPUT 2 is required, continue pressing the ENTER key until OUTPUT 2 SPAN is displayed.
7. Using the arrow keys as explained in step 5, adjust the output to read 20mA on the multimeter. This output level can be adjusted from the minimum output setting up to 20mA if another range is required.
8. Press the SETUP key to save the calibration values and exit the calibration routine.

## Process Calculations

### Oxygen Process Control

Oxygen:

$$\%O_2 = \frac{20.95}{e^{(E/0.0215 \cdot T_k)}}$$

Where:

E = probe millivolts + mv offset, T<sub>k</sub> = probe temperature in degrees Kelvin.  
20.95 is the %O<sub>2</sub> in air.

## Digital Communications

This section describes the Marathon protocol that is available in the Versapro. This protocol emulates the 10Pro series and Unipro instruments. The 10Pro series instrument includes the 10Pro, 10Pulse, 10Pro-E, and 10Pro-L instruments. These instruments are single loop controllers that typically control temperature or speed. When they are connected to the host bus they will not initiate any message but will only respond if both the address, instrument letter, and message format are correct.

It is possible for some instruments to respond to multiple instrument type letters. The Unipro, and 10Pro series instrument and Versapro can respond to the 10Pro Emulation Mode. In the future the MMI mode or block mode and Modbus will be added to the Versapro's capabilities.

The transmission format for the MSI Emulation mode is 7 bits, even parity, 1 stop bit. All determinations of the delimiter and LRC are based on the character values before the parity bit is added. The Versapro maximum baud rate is limited to 19.2K baud.

The Marathon Sensors 10Pro Emulation message protocol is determined by the source of the transmission. The following format is used by the HOST to request data from the instrument. NOTE: no data field is required.

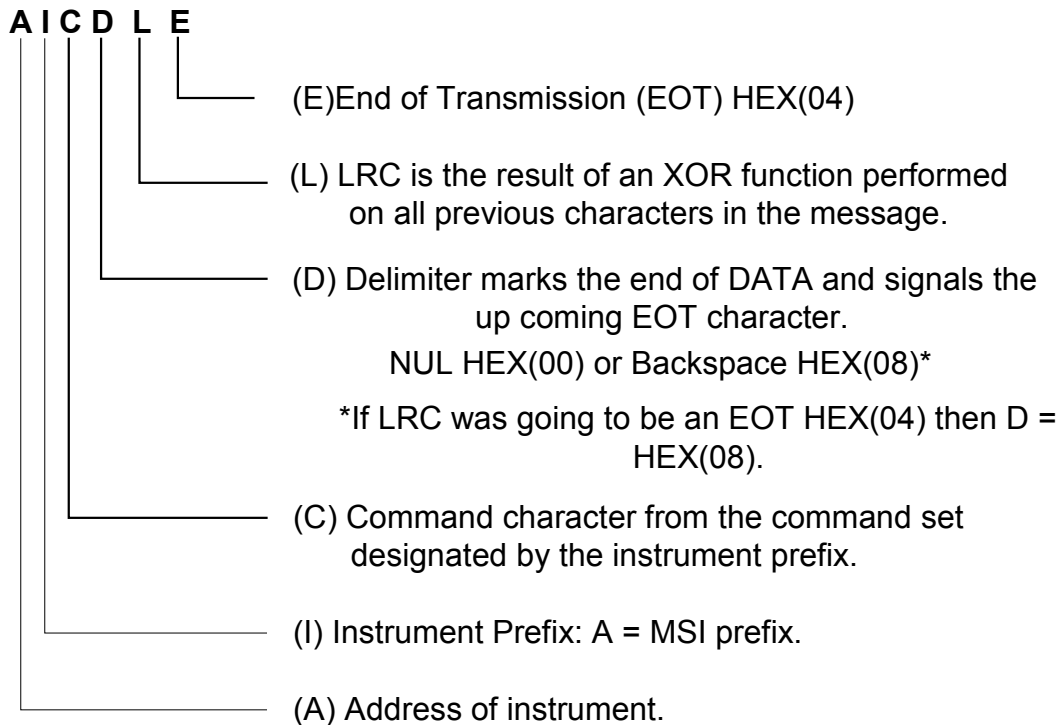

### Instrument Address Range

ASCII or BROADCAST MODE  
0 – F (15)      ? character  
or  
@ character

The LRC is the exclusive OR of hex values of all the characters in the message including the delimiter but not the EOT. The delimiter is normally a hex 00 unless the LRC for the message would be a hex 04 (EOT). If the LRC is calculated to be a hex 04, then the delimiter is set to a hex 08 which makes the LRC a hex 0C. No character in the message can be a hex 04 except the EOT.

If an error free and valid message is received by the VersaPro, it will respond with the first character being an (ACK) HEX(06). It then echoes the message received, inserting any requested data. If an error was detected or an invalid request made, the first character sent is a (NAK) HEX(15).

All instrument responses are delayed by a minimum of 20 milliseconds to allow time for the transmitters to be turned off.

The instrument has an independent 300 millisecond time-out timer. This timer is reset by the receipt or transmission of a character. Should the timer time-out, all buffers should be cleared, pointers reset, and the UART re-setup.

The following format is generated by the HOST when parameters are changed in the instrument or when the instrument is responding to the HOST request. Any change commands from the HOST are echoed by the instrument in the same format as the data that was sent.

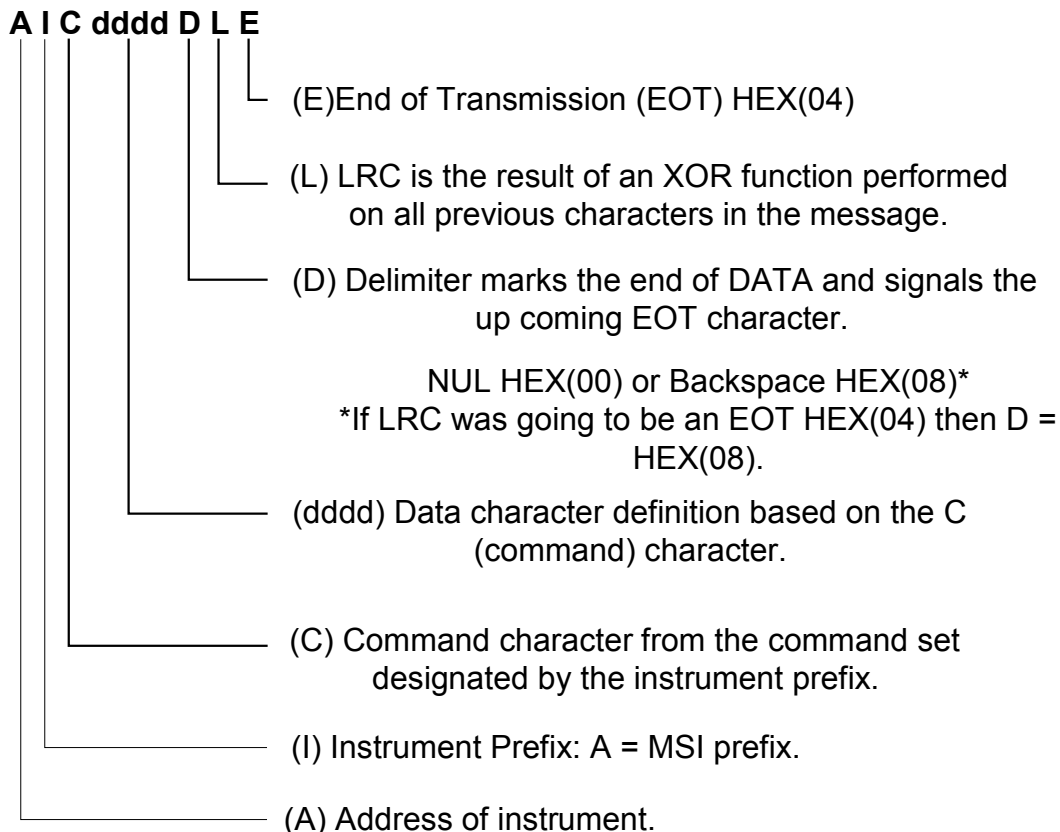

The MSI (Marathon Sensors Inc.) command set supports the extensive capabilities of the MSI line of slave instruments. The command set consists of the typical characters shown in the following table. These commands are used when the master instrument or server issues an ‘A’ prefix with the command when requesting a single parameter. This command structure is used with other slave instruments such as the 10Pro-T, 10ProE, CarbPC, and 10ProL. The typical commands that are issued are p, o, i, h, l, and m. The master issues updates to the Versapro when required.

**Table 19 MSI Command Set for ‘A’ Type Instruments**

<b>COMMAND LETTER</b>	<b>Process (oxygen, carbon, temp, etc.)</b>	<b>Timer</b>	<b>Returned Value</b>
p (low case)	Read Auto / Manual mode	Same	‘A’ = auto or remote ‘B’ = manual
o (low case)	Read Remote / Local	Same	‘A’ = auto or manual ‘B’ = remote
i (low case)	Read Remote Process	Read Remote Time	4 digit ASCII

## Marathon Sensors Inc.

COMMAND LETTER	Process (oxygen, carbon, temp, etc.)	Timer	Returned Value
	Setpoint	Setpoint	number
h (low case)	Read Auto Process Setpoint	Read Auto Time Setpoint	4 digit ASCII number
l (lower case as in limits)	Read Actual Process	Read Remaining Time	4 digit ASCII number
m (low case)	Read % Output	Read Time control byte	4 digit ASCII number
I (upper case as in Instrument)	Update Process Setpoint Temporarily	Update Time Setpoint Temporarily	4 digit ASCII number
J (upper case)	Update Process Setpoint Permanently	Update Time setpoint Permanently	4 digit ASCII number
M	Set % Output and force Manual Mode	No Effect	4 digit ASCII number of % output.
P (upper case)	Update Auto / Manual mode	Same	'A' = forces a remote 'B' = forces a manual

Notes: 1) All READ commands are lower case letters. All UPDATE commands are upper case letters.

2) All numeric data are in returned as ASCII characters of decimal numbers.

Here is an example of a typical data exchange between a host or master and the Versapro using the 'A' prefix. The hexadecimal values of the command and response messages are shown in the second line to illustrate the actual values used to calculate the LRC. The LRC is calculated by doing an exclusive OR on all of the hexadecimal values in the message up to the delimiter.

This is the command and response for reading the actual process value of the Versapro. In this example the instrument address is 2 and the return value is 0071. Typically this would be 00.71% oxygen. Other parameters and scaling are available if the linear inputs are selected. In general the number that is returned is the number displayed on the instrument. No decimal point information is available.

Transmit from Host or Master

Add	Prefix	Cmd	Delim	LRC	
2	A	1	<NUL >L>	<HEX 1F >	<EOT>

## Marathon Sensors Inc.

---

0x32	0x41	0x6C	0x00	0x1F	0x04
------	------	------	------	------	------

### Response from Versapro

	Add	Prefix	Cmd	D1	D2	D3	D4	Delim	LRC	
<ACK >	2	A	1	0	0	7	1	<NUL L>	<HEX 1F >	<EOT >
0x06	0x32	0x41	0x6C	0x3 0	0x3 0	0x3 7	0x3 1	0x00	0x1F	0x04

Here is an example of a request and response for the local setpoint of the instrument in Automatic mode. The response indicates that the instrument's address is 2 and the local setpoint is 1500.

### Transmit from Host or Master

Add	Prefix	Cmd	Delim	LRC	
2	A	h	<NUL L>	<HEX 1B >	<EOT >
0x32	0x41	0x68	0x00	0x1B	0x04

### Response from Versapro

	Add	Prefix	Cmd	D1	D2	D3	D4	Delim	LRC	
<ACK >	2	A	h	1	5	0	0	<NUL L>	<HEX 19 >	<EOT>
0x06	0x32	0x41	0x68	0x3 1	0x3 5	0x3 0	0x3 0	0x00	0x19	0x04

Here is an example that shows how the HOST changes the instrument's remote set point. The instrument's address is 15. The HOST has sent a command to update the remote setpoint with 1450. The instrument responds by echoing the command.

### Transmit from Host or Master

Add	Prefix	Cmd	D1	D2	D3	D4	Delim	LRC	
F	A	I	1	4	5	0	<NUL L>	N	<EOT>
0x46	0x41	0x49	0x3 1	0x3 4	0x3 5	0x3 0	0x00	0x4E	0x04

### Response from Versapro

	Add	Prefix	Cmd	D1	D2	D3	D4	Delim	LRC	
--	-----	--------	-----	----	----	----	----	-------	-----	--

## Marathon Sensors Inc.

---

<ACK >	F	A	I	1	5	0	0	<NUL L>	H	<EOT>
0x06	0x46	0x41	0x49	0x3 1	0x3 4	0x3 5	0x3 0	0x00	0x48	0x04

## Technical Specification

### Environmental ratings

Panel sealing: Instruments are intended to be panel mounted. The rating of panel sealing is IP64.

Operating temperature: 0 to 55°C. Ensure the enclosure provides adequate ventilation.

Relative humidity: 5 to 95%, non condensing.

Atmosphere: The instrument is not suitable for use above 2000m or in explosive or corrosive atmospheres.

### Equipment ratings

Supply voltage: 100 to 240Vac -15%, +10%

Supply frequency: 48 to 62Hz.

Power consumption: 15 Watts maximum.

Relay 2-pin (isolated): Maximum: 264Vac, 2A resistive. Minimum: 12Vdc, 100mA.

Relay changeover (isolated): Maximum: 264Vac, 2A resistive. Minimum: 6Vdc, 1mA.

Over current protection: External over current protection devices are required that match the wiring of the installation. A minimum of 0.5mm<sup>2</sup> or 16awg wire is recommended. Use independent fuses for the instrument supply and each relay output. Suitable fuses are T type, (EN 60127 time-lag type) as follows;  
Instrument supply: 85 to 264Vac, 2A, (T).  
Relay outputs: Triac outputs: 1A (T).

Low level I/O: All input and output connections are intended for low level signals less than 24VDC.

DC output (Isolated): 0 to 20mA (650Ω max), 0 to 10V (using a 500Ω dropping resistor).

Fixed digital inputs: Contact closure. (Non isolated.)

Transmitter supply: 30Vdc at 20mA. (Isolated.)

Digital Comms: EIA-232, 2-wire EIA-485 or 4-wire EIA-485 (All isolated).

### General

Thermocouple input: Type B, K, R, and S accuracy after linearization +/- 1 deg F

Probe input: 0 to 2000 millivolts +/- 0.1 millivolt

Input A range: -70mV to +77mv (Isolated.)

Input B input: -999mV to 2100mV (Isolated.)

Cold junction compensation 0 to 60°C +/- 1 deg F

Calibration accuracy: The greater of ±0.2% of reading, ±1 LSD or ±1°C.

Isolation 1000V DC/AC  
Power input to signal inputs

## Marathon Sensors Inc.

---

Calculations	Power input to communications Percent carbon 0 – 2.55% (no CO compensation) Dewpoint -99 – 212 °F (no hydrogen compensation) Percent oxygen. 0 – 25.0% (Small oxygen concentrations can be measured by changing the exponent setting.)
Accuracy	+/- 1% of LSD of process value.
Probe Care	Probe verification and impedance for oxygen probes.
Communications port	RS-485 Half Duplex Only
Protocol	10Pro, MMI block transfer, or Modbus RTU
Baud rates	1200, 2400, 4800, 9600, 19.2K, or 38.4K
Parity	Even or None
Control Mode	Time Proportioning Single Contact Direct Time Proportioning Single Contact Reverse Time Proportioning Dual Contact Direct Time Proportioning Dual Contact Reverse Position Proportioning Direct Position Proportioning Reverse On / Off Direct On / Off Reverse
Alarm Type (both Alarm 1 and 2)	High Limit Temp Low Limit Temp Process Deviation Band Process Deviation High Process Deviation Low Control Percent Out Input Fault (mV or Thermocouple)
Digital Event Input (isolated contact closure)	Probe Burnoff Manual/Auto Local/Remote Alarm Acknowledgement
<b>Electrical safety (pending approval)</b>	
Standards:	EN 61010, Installation category II, pollution degree 2.
Installation category II:	Voltage transients on any mains power connected to the instrument must not exceed 2.0 kV.
Pollution degree 2:	Conductive pollution must be excluded from the cabinet in which the instrument is mounted.

## Marathon Sensors Inc.

---

### Environmental Conditions

Operating Temperature	-20 °C to 65 °C (-4 to 176 F)
Storage Temperature	-40 °C to 85 °C (-40 to 185 F)
Operating and Storage Humidity	85% max relative humidity, noncondensing, from -20 to 65°C

### Electromagnetic Compatibility (pending approval)

#### Immunity

Electrostatic discharge	EN 61000-4-2	Level 2: ±8 kV air Level 2: ±4 kV contact
Electromagnetic RF fields	EN 61000-4-3	Level 3: 10 V/m 80 MHz – 1000 MHz
Fast Transients	EN 61000-4-4	Level 3: ±1 kV I/O Level 3: ±2 kV power
RF conducted interference	EN 61000-4-6	Level 3: 10 V/rms 150 KHz – 80 MHz
Power Freq Magnetic Fields	EN 61000-4-8	30 A/m, x y z planes
Surge	EN 61000-4-5	±1kV L-L, ±2kV L-PE 5 / min at 0°, 90°, 270°
Voltage Variations	EN 61000-4-11	70% of operating voltage 0.5 cycles/10ms

#### Emissions

RF Emissions	CSIPR Class B
Conducted Emissions	CISPR Class B
Harmonic Current Emissions	EN 61000-3-2
Voltage Fluctuation	EN 61000-3-3

Note: Specifications may change without notification.