

**Marathon Monitors Inc.**

**10 PRO-e Controller**

Installation and Operation Handbook



COPYRIGHT © 1998

MARATHON MONITORS INC.

# MARATHON MONITORS INC.

---

Part # F200035

COPYRIGHT © 1997

MARATHON MONITORS INC.

3100 East Kemper Road, Cincinnati, Ohio 45241

1-800-322-4444

(513) 772-7788

FAX: (513) 772-7853

No part of this document may be stored or reproduced by any means whatsoever without prior written permission of Marathon Monitors Inc.

All trademarks used in this publication are duly marked and the sole property of their respective owners. No attempt at trademark or copyright infringement is intended or implied.

Marathon Monitors makes no warranties express or implied beyond the written warranty presented at initial purchase. Marathon Monitors Inc. is not responsible for any product, process, damage or injury incurred while using this equipment. Marathon Monitors makes no representations or warranties with respect to the contents hereof and specifically disclaims any warranties of merchantability or fitness for any particular application or purpose.

Revision Date: 06-02-98

Revision Number: 1.3

# MARATHON MONITORS INC.

---

## Contents

Safety and EMC Information.....	4
Chapter 1 <b>INSTALLATION</b> .....	<b>10</b>
Chapter 2 <b>OPERATION</b> .....	<b>18</b>
Chapter 3 <b>TIMER FUNCTIONS</b> .....	<b>34</b>
Chapter 4 <b>ACCESS LEVELS</b> .....	<b>38</b>
Chapter 5 <b>TUNING</b> .....	<b>44</b>
Chapter 6 <b>CONFIGURATION</b> .....	<b>50</b>
Chapter 7 <b>USER CALIBRATION</b> .....	<b>62</b>

“This product is covered by one or more of the following US Patents:

5,484,206; Additional patents pending.”

# MARATHON MONITORS INC.

---

## **SAFETY and EMC INFORMATION**

Please read this section before installing the controller

This controller meets the requirements of the European Directives on Safety and EMC; however, it is the responsibility of the installer to ensure the safety and EMC compliance of any particular installation.

### **Safety**

This controller complies with the European Low Voltage Directive 73/23/EEC, amended by 93/68/EEC, by the application of the safety standard EN 61010(93).

### **Electromagnetic compatibility**

This controller conforms with the essential protection requirements of the EMC Directive 89/336/EEC, amended by 93/68/EEC, by the application of a technical construction file.

### **INSTALLATION REQUIREMENTS FOR EMC**

This unit satisfies the emissions and immunity standards for industrial environments.

To ensure compliance with the European EMC directive, certain installation precautions are necessary as follows:

- For general guidance refer to the EMC Installation Guide, HA025464.
- When using relay or triac outputs, it may be necessary to fit a filter suitable for suppressing the conducted emissions. The filter requirements will depend on the type of load. For typical applications we recommend Schaffner FN321 or FN612.
- If the unit is used in table top equipment which is plugged into a standard power socket, then it is likely that compliance to the commercial and light industrial emissions standard is required. In this case, to meet the conducted emissions requirement, a suitable mains filter should be installed. We recommend Schaffner types FN321 and FN612.

# MARATHON MONITORS INC.

## Routing of wires

To minimize the pick-up of electrical noise, the low voltage DC connections and the sensor input wiring should be routed away from high-current power cables as shown below. Where it is impractical to do this, use shielded cables with the shield grounded at both ends.

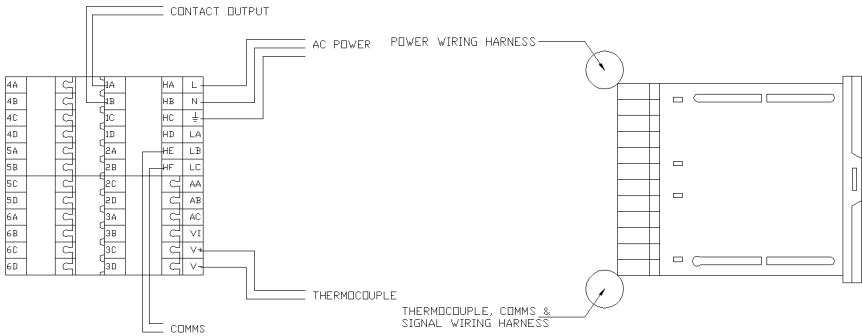

## SERVICE AND REPAIR

This controller has no user serviceable parts. Contact your nearest Marathon Monitors agent for repair.

# MARATHON MONITORS INC.

---

## TECHNICAL SPECIFICATION FOR SAFETY PURPOSES

### Equipment ratings

Supply voltage:	100 to 240Vac -15%, +10%
Supply frequency:	48 to 62Hz
Power consumption:	10Watts maximum
Relay ratings:	Min: 100mA at 12Vdc. Max: 2A resistive at 264Vac
Triac output:	1A resistive max at 30 to 264Vac
Leakage current:	The leakage current through the external 'snubber' supplied to suppress voltage spikes on triac and relay contact outputs is less than 2mA at 264Vac, 50Hz
Over current protection:	External over current protection devices are required that match the wiring of the installation A minimum of 0.5mm <sup>2</sup> or 16awg wire is recommended Use independent fuses for the instrument supply and each relay or triac output Suitable fuses are T type, (IEC 127 time-lag type) as follows; Instrument supply: 85 to 264Vac, 2A, (T) Relay outputs: 2A (T). Triac outputs: 1A (T)
Low level I/O:	All other input and output connections are intended for low level signals at less than 42V

### Environmental ratings

Panel sealing:	The controller is intended to be panel mounted. The rating of panel sealing is defined by EN 60529: IP 65
Operating temperature:	0 to 55°C. Ensure the enclosure provides adequate ventilation
Relative humidity:	5 to 90%, non condensing
Atmosphere:	The instrument is not suitable for use above 2000m or in explosive or corrosive atmospheres

### Electrical safety

Safety Standard:	Meets EN 61010, Installation category II, pollution degree 2 Voltage transients on any mains power connected to the instrument must not exceed 2.5kV Electrically conductive pollution must be excluded from the cabinet in which the instrument is mounted
Isolation:	All isolated inputs and outputs, have a reinforced isolation which provides protection against electric shock Non-isolated logic connections are electrically connected to the main process variable input, (e.g. the thermocouple)

# MARATHON MONITORS INC.

---

## Safety Symbols

Various symbols are used on the instrument, they have the following meaning:



Caution, (refer to the accompanying documents)



Functional earth (ground) terminal

A functional earth means one that is not required for safety purposes but is used for some functional purpose such as grounding EMC filters.

## INSTALLATION SAFETY REQUIREMENTS

### Personnel

Installation must only be carried out by qualified personnel.

### Enclosure of live parts

To prevent hands or metal tools touching parts that may be electrically live, the controller must be installed in an enclosure.

### Wiring

It is important to connect the controller in accordance with the wiring data given in this handbook. Take particular care not to connect AC supplies to the low voltage sensor input, DC, or logic inputs and outputs. Wiring installations must comply with all local wiring regulations.

### Isolation

The installation must include a power isolating switch or circuit breaker. This device should be in close proximity to the controller, within easy reach of the operator and marked as the disconnecting device for the instrument.

### Overcurrent protection

To protect the internal PCB tracking within the controller against excess currents, the AC power supply to the controller and power outputs must be wired through the fuse or circuit breaker specified in the technical specification.

### Voltage rating

The maximum continuous voltage applied between any of the following terminals must not exceed 264Vac:

- line or neutral to any other connection
- relay or triac output to logic, DC or sensor input connections
- any connection to ground

# MARATHON MONITORS INC.

---

The controller should not be wired to a three phase supply with an unearthed star connection. Under fault conditions such a supply could rise above 264Vac with respect to ground and the product would not be safe.

Voltage transients across the power supply connections, and between the power supply and ground, must not exceed 2.5kV. Where occasional voltage transients over 2.5kV are expected or measured, the power installation to both the instrument supply and load circuits should include a transient limiting device.

These units will typically include gas discharge tubes and metal oxide varistors that limit and control voltage transients on the supply line due to lightning strikes or inductive load switching. Devices are available in a range of energy ratings and should be selected to suit conditions at the installation.

## **Conductive pollution**

Electrically conductive pollution must be excluded from the cabinet in which the controller is mounted. For example, carbon dust is a form of electrically conductive pollution. To secure a suitable atmosphere, install an air filter to the air intake of the cabinet. Where condensation is likely, for example at low temperatures, include a thermostatically controlled heater in the cabinet.

## **Grounding**

The non-isolated logic has an electrical path to the sensor input. Because of this, two possible conditions need to be considered:

- The temperature sensor may be connected to the electrical heating element and hence be at the heater supply voltage. The controller is designed to operate under these conditions; however, the non-isolated logic input will also be at the heater potential. You must ensure that this will not damage the power control device that is connected to the logic output and that someone servicing the equipment does not touch the sensor, or the non-isolated logic connections while they are live.
- In some installations it is common practice to replace the temperature sensor while the controller is still powered up. Under these conditions, we recommend that the shield of the temperature detector is grounded. Do not rely on grounding through the framework of the machine.

## **Electrostatic discharge precautions**

When the controller is removed from its sleeve, some of the exposed electronic components are vulnerable to damage by electrostatic discharge from someone handling the controller. To avoid this, before handling the unplugged controller discharge yourself to ground.

## **Over-temperature protection**

# MARATHON MONITORS INC.

---

When designing any control system it is essential to consider what will happen if any part of the system should fail. In temperature control applications the primary danger is that the heating will remain constantly on. Apart from spoiling the product, this could damage any process machinery being controlled, or even cause a fire.

Reasons why the heating might remain constantly on include:

- the temperature sensor becoming detached from the process
- the controller failing with its heating output constantly on
- an external valve or contactor sticking in the heating condition
- the controller setpoint set too high

Where damage or injury is possible, we recommend fitting a separate over-temperature protection unit, with an independent temperature sensor, which will isolate the heating circuit.

Please note that the alarm relays within the controller will not give protection under all failure conditions.

## Chapter 1 INSTALLATION

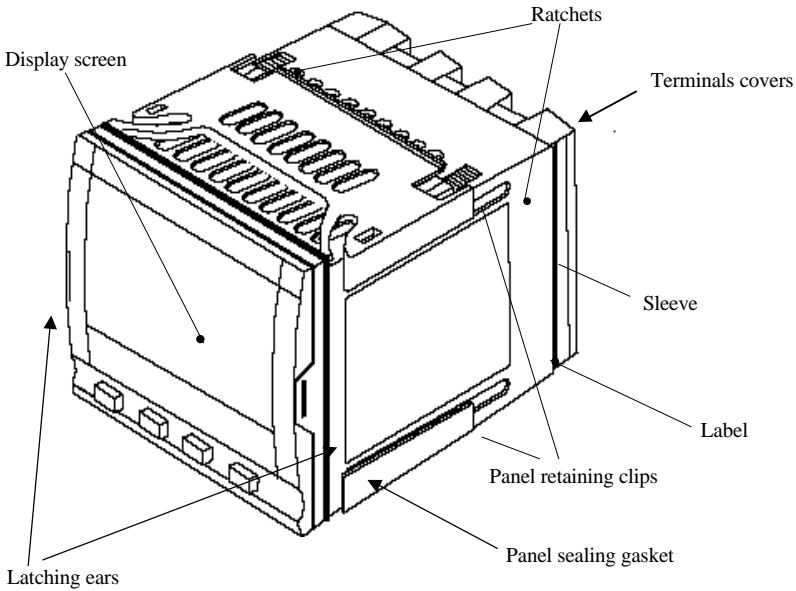

Figure 1-1  
Model 10PRO-e 1/4 DIN controller

### Outline dimensions Model 10PRO-e

# MARATHON MONITORS INC.

---

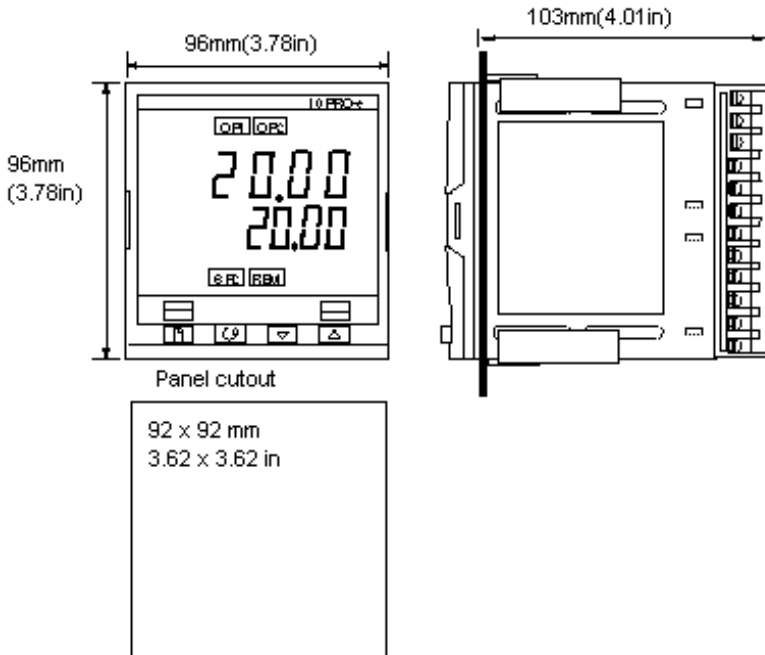

FIGURE 1-2

The electronic assembly of the controller plugs into a rigid plastic sleeve, which in turn fits into the standard DIN size panel cut-out shown in Figure 1-2.

# MARATHON MONITORS INC.

---

## INTRODUCTION

The Model 10PRO-e is a precision temperature controller with self tuning. It has a modular hardware construction which provides two control outputs, two alarm relays and one communications port. Two logic inputs are provided as standard. In addition the controller has an optional plug-in 10A heating output.

**Before installing the controller, please read *Safety Information on page (3)***

### Controller labels

The labels on the sides of the controller identify the ordering code, the serial number, and the wiring connections.

## MECHANICAL INSTALLATION

### To install the controller

1. Prepare the control panel cut-out to the size shown in Figure 1-1.
2. Insert the controller through the panel cut-out.
3. Spring the upper and lower panel retaining clips into place. Secure the controller in position by holding it level and pushing both retaining clips forward.

Note: If the panel retaining clips subsequently need removing, in order to extract the controller from the control panel, they can be unhooked from the side with either your fingers or a screwdriver.

### Unplugging and plugging-in the controller

If required, the controller can be unplugged from it's sleeve by easing the latching ears outwards and pulling it forward out of the sleeve. When plugging the controller back into it's sleeve, ensure that the latching ears click into place in order to secure the IP65 sealing.

## ELECTRICAL INSTALLATION

This section consists of four topics:

- Wiring connections
- Outputs 1 and 2 connections
- Communications connections
- Typical wiring diagram

---

## WARNING

**Before installing the controller you must ensure that it is correctly configured for your application. Incorrect configuration could result in damage to the process being controlled, and/or personal injury. The controller may either have been configured when ordered, or may need configuring now.**

---

# MARATHON MONITORS INC.

## Wire Sizes

All electrical connections are made to the screw terminals at the rear of the controller. If you wish to use crimp connectors, the correct size is AMP part number 165004. They accept wire sizes from 0.5 to 1.5 mm<sup>2</sup> (16 to 22 awg). A set of connectors are supplied with the controller. The terminals are protected by a clear plastic hinged cover to prevent hands or metal making accidental contact with live wires.

## Wiring connections

The wiring connections are shown in Figure 1-3.

Please note that outputs 1 and 2 can be any one of the types shown in figure 1-5.

The ground connection is provided as a return for internal EMC filters. It is not required for safety purposes, but must be connected in order to satisfy EMC requirements.

## Model 10PRO-e connection

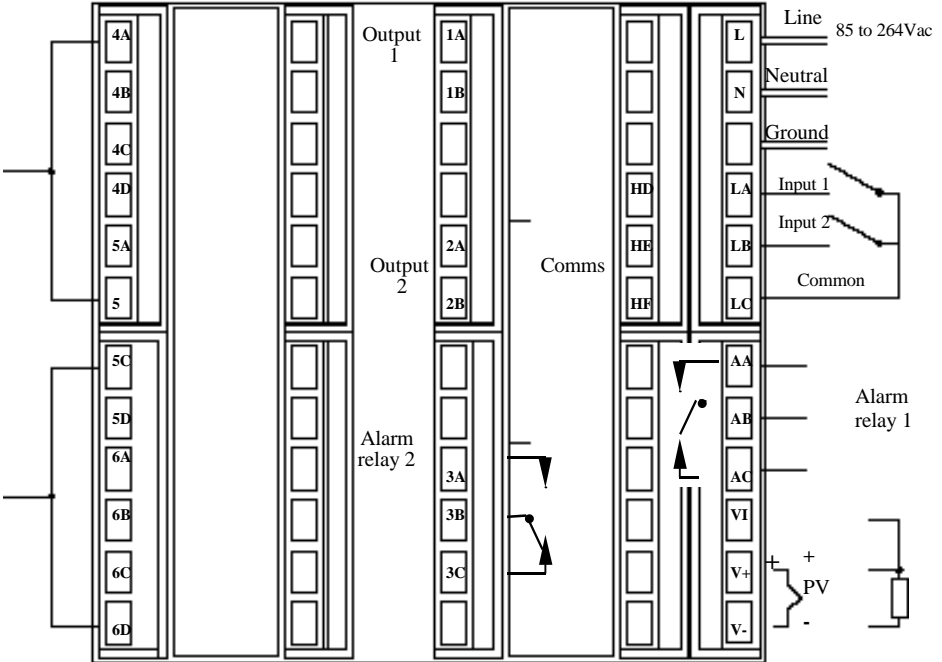

Model 10PRO-e Wiring connections

# MARATHON MONITORS INC.

---

## Sensor input connections

The connections for the various types of input are as follows:

Thermocouple

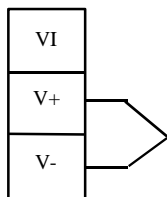

Resistance thermometer

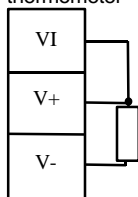

mA input

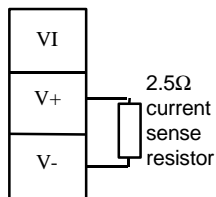

Volts or mV inputs

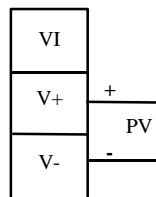

## Sensor input connections

**WARNING:** If parallel connections of a thermocouple are made between the 10Pro-e and another instrument (i.e. recorder), be sure to turn off the sensor break detection in the other instrument. Sensor break detectors can insert a signal on the thermocouple wire which can cause erratic readings and improper control.

# MARATHON MONITORS INC.

## OUTPUTS 1 AND 2 CONNECTIONS

Outputs 1 and 2 can be any one of the possible types shown in table below configured to perform any of the functions shown in the table.

To check which outputs are installed in your particular controller, and which functions they are configured to perform, refer to the ordering code and the wiring information on the controller side labels.

Module type	Connections				Possible functions
	Output 1		Output 2		
	1A	1B	2A	2B	
Relay: 2-pin (2A, 264 Vac max.)					Heating Cooling Valve Positioning Alarms
Logic: non-isolated (18Vdc at 24mA)					Heating Cooling Alarms
Triac (1A, 30 to 264Vac)					Heating Cooling Valve Positioning
DC control: isolated (12Vdc, 20mA max)			DC not available in output 2		Heating or cooling

### Outputs 1 and 2 connections

# MARATHON MONITORS INC.

---

## Snubbers

The controller is supplied with 'snubbers'(15nF +100Ω) which should be wired across the relay or triac outputs when switching inductive loads such as mechanical contactors and solenoid valves. The snubbers are used to prolong contact life and to suppress interference when switching such loads. Do not use snubbers when switching high impedance loads. The snubbers pass 0.6mA at 110Vac and 1.2mA at 240Vac. This may be sufficient to hold in high impedance relay coils and should not be used in such installations.

---

### WARNING

When a relay contact is used in an alarm circuit it is the user's responsibility to ensure that the current passing through the snubber when the relay contact is open does not hold in low power electrical loads and thereby interfere with the failsafe operation of the alarm circuit.

---

## COMMUNICATIONS CONNECTIONS

The communications option can either of two types shown in the table below

Communications type	Connection		
	HD	HE	HF
EIA 485 serial communications	Common	A NEG -	B POS +

Communication connections

# MARATHON MONITORS INC.

## Wiring of EIA-485 serial communication links

EIA 485 is a 2-wire connection which allows up to 16 controllers to be multi-dropped from a single communications link over a distance of up to 1.2Km. To ensure reliable operation of the communications link, (without data corruption due to noise or line reflections) the connections between the controller should be made using a twisted pair of wires inside a screened cable with the connections terminated with resistors in the manner shown in this diagram.

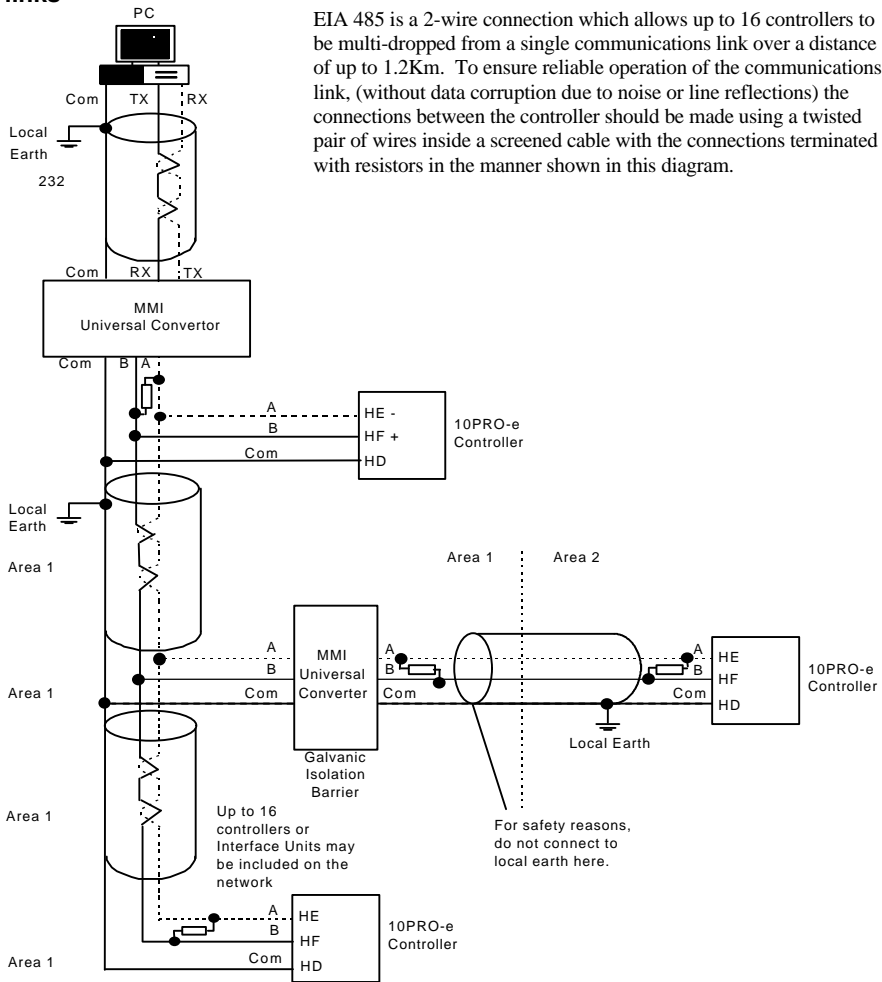

Note:  
 All resistors are 220 ohm 1/4W carbon composition.  
 Local grounds are at equipotential. Where equipotential is not available wire into separate zones using a galvanic isolator.

### EIA-485 wiring



## Chapter 2 OPERATION

\This chapter has nine topics:

- FRONT PANEL LAYOUTS
- OPERATING MODES
- POWER ON
- AUTOMATIC MODE
- MANUAL MODE
- PARAMETERS AND HOW TO ACCESS THEM
- NAVIGATION DIAGRAM
- PARAMETER TABLES
- ALARM MESSAGES

# MARATHON MONITORS INC.

## FRONT PANEL LAYOUT

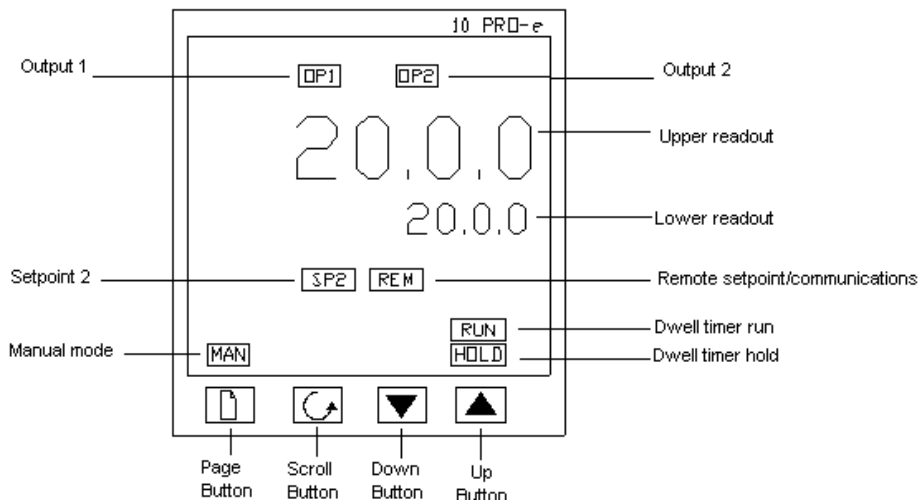





**Model 10PRO-e front panel layout**

Button or indicator	Name	Explanation
OP1	Output 1	When lit, this indicates that output 1 is on. This is normally the heating or valve open output.
OP2	Output 2	When lit, this indicates that output 2 is on. This is normally the cooling or valve closed output.
SP2	Setpoint 2	When lit, this indicates that setpoint 2 has been selected.
REM	Remote setpoint	When lit, this indicates that a remote device is using MMI communications to control the setpoint.
MAN	Manual light	When lit, this indicates that manual mode has been selected
RUN	Run light	When lit, this indicates Dwell timer is RUNNING
HOLD	Hold Light	When lit, this indicates Dwell timer in HOLD.

# MARATHON MONITORS INC.

---

	Page button	Press to select a new list of parameters.
	Scroll button	Press to select a new parameter in a list.
	Down button	Press to decrease a value in the lower readout.
	Up button	Press to increase a value in lower readout.

## OPERATING MODES

The controller has two basic modes of operation:

- **Automatic mode** in which the output power is automatically adjusted to maintain the temperature at the setpoint.
- **Manual mode** in which you can adjust the output power independently of the setpoint.

The displays which appear in each of these modes are explained in this chapter.

One other mode is also available:

- **Remote Setpoint mode** in which the setpoint and other parameters are established by MMI Communications. In this mode the REM light will be on. Note: Setpoint 2 must be selected to enable the remote mode.



# MARATHON MONITORS INC.

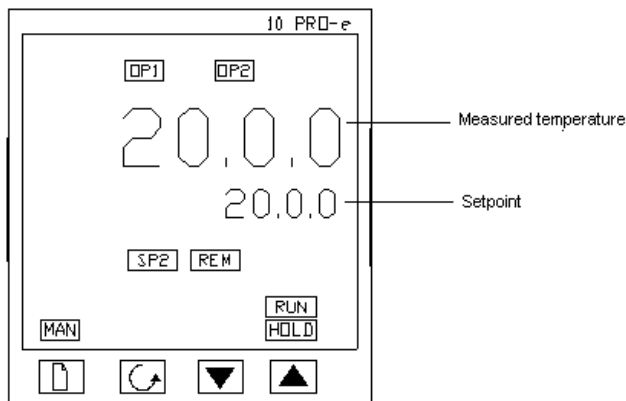

---

## POWER ON

Switch on the power to the controller. It runs through a self-test sequence for about three seconds and then shows the temperature or process value in the upper readout and the setpoint in the lower readout. This is called the Home display.



On this display you can adjust the setpoint by pressing the  or  buttons. Two seconds after releasing either button, the display blinks to show that the controller has accepted the new value.

Note: You can get back to the Home display at any time by pressing  and  together. Alternatively you will always be returned to the Home display if no button is pressed for 45 seconds or whenever the power is turned on.

## Alarms

If the controller detects an alarm condition, it flashes an alarm message in either the upper or lower readout of the Home display. For a list of all the alarm messages, their meaning and what to do about them, see *alarms* at the end of this chapter

# MARATHON MONITORS INC.

## AUTOMATIC MODE

You will normally work with the controller in automatic mode. In this mode the 'MAN' light will be Off.

Power on

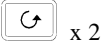
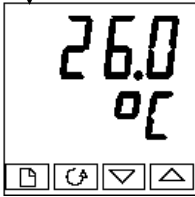

The Home display

Check that the MAN light is off.

The upper readout shows the measured temperature. The lower readout shows the setpoint.

To adjust the setpoint up or down, press

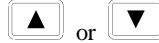

To speed up the rate of change keep the button pressed

*Press the Scroll button once*

### Display units



A single press of the  button will flash the display units for 0.5 seconds, after which you will be returned to the Home display.

Flashing of the display units may have been disabled in configuration in which case a single press will take you straight to the display shown below.

*Press the Scroll button twice*

### % Output power demand

The % output power demand is displayed in the lower readout. This is read-only value. You cannot adjust it.

Press  and  together to return to the Home display.

*Press the Scroll button*

Pressing the *Scroll* button from the Output Power display may access further parameters. Other parameters may be in this scroll list if the 'promote' feature has been used (see *Edit Level*, Chapter 3).

When you reach the end of this scroll list pressing the Scroll button will return you to the Home display

# MARATHON MONITORS INC.

## MANUAL MODE

### IN MANUAL MODE THE MAN LIGHT WILL BE ON.

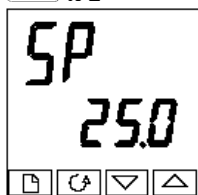
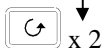
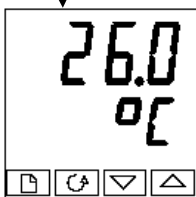
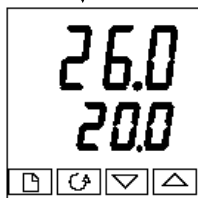

(Manual mode is selected by setting the parameter 'm - A' in the Home list to 'on' see the next section Parameters and how to access them)

Power on



### The Home display

Check that the MAN light is on. The upper readout shows the measured temperature or process value. The lower readout shows the % output.

To adjust the output, press  or .



*Press the Scroll button once*

### Display units

A single press of the  button will flash the display units for 0.5 seconds, after which you will be returned to the Home display. Flashing of the display units may have been disabled in configuration in which case a single press will take you straight to the display shown below.

*Press the Scroll button twice*

### Setpoint

To adjust the setpoint value, press  or .

*Press the Scroll button*

pressing the scroll button from the output power display may access other parameters other parameters may be in this scroll list if the 'promote' feature has been used (see edit level, chapter 4).when you reach the end of this scroll list pressing the scroll button will return you to the home display



# MARATHON MONITORS INC.



---

## PARAMETERS AND HOW TO ACCESS THEM

Parameters are settings within the controller that determine how the controller will operate. For example, alarm setpoints are parameters that set the points at which alarms will occur. For ease of access, the parameters are arranged in lists as shown in the navigation diagram on the following page. The names of these lists are called the *list headers*. The lists are:

<i>Home list</i>	<i>Setpoint list</i>	<i>On/Off list</i>
<i>Alarm list</i>	<i>Input list</i>	<i>Communications list</i>
<i>PID list</i>	<i>Output list</i>	<i>Access list t</i>

**To step through the list headers** press the Page button . You can recognize a list header by the fact that it always shows 'LiSt' in the lower readout. Depending upon how your controller has been configured, a single press may momentarily flash the display units. In this case, a double press will be necessary to take you to the first list header. Continued pressing of the  button will step through the list headers, eventually returning you to the Home display.



**To step through the parameters** within a particular list, press the Scroll button . When you reach the end of the list, you will return to the list header. From within a list you can return to the list header at any time by pressing the Page button . To step to the next list header press the Page button  once again.

### Parameter names

In the navigation diagram, each box depicts the display for a selected parameter. The upper readout shows the name of the parameter and the lower readout it's value. The Operator parameter tables later in this chapter list all the parameter names and their meaning. The navigation diagram shows all the parameters that *potentially* can be present in the controller. In practice, only those associated with a particular configuration will appear. The shaded boxes in the diagram indicate parameters that are hidden in normal operation. To see all the available parameters, you must select 'Full' access level. For more information about this, see Chapter 3, *Access Levels*.

### To change the value of a parameter

First, select the required parameter. The parameter name is shown in the upper readout and the parameter value in the lower readout.

To change the parameter value, press either  or . In this adjustment, single presses change the value by one digit. Keeping the button pressed speeds up the rate of change.

Two seconds after releasing either button, the display blinks to show that the controller has accepted the new value

# MARATHON MONITORS INC.

## NAVIGATION DIAGRAM (PART A)

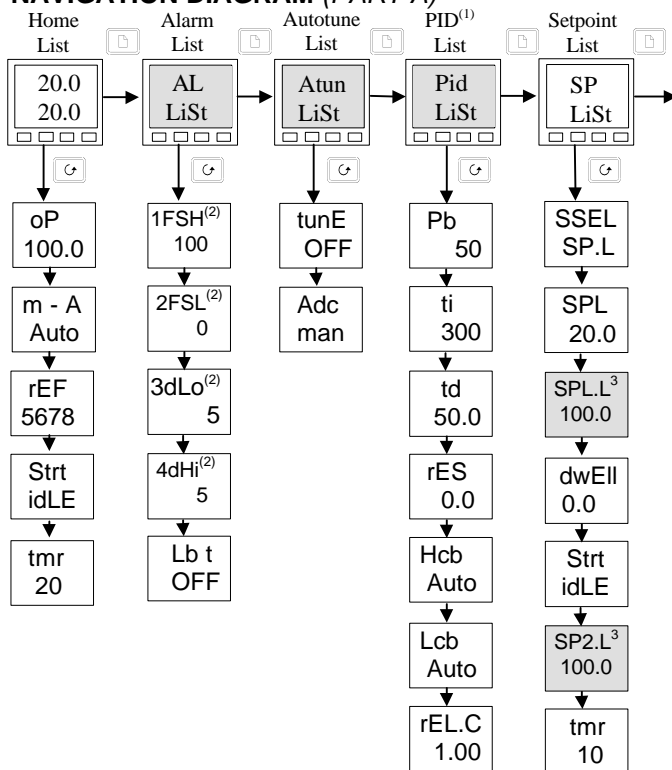

### Notes:

1. Either the PID list or the On/Off list will be present depending upon the type of control in use.
2. The last three characters depend upon the type of alarm configured.
3. **Beware!** Used for calibration.  
The shaded boxes are normally hidden in Operator level. To see all the available parameters you must select Full level.

# MARATHON MONITORS INC.

## NAVIGATION DIAGRAM (PART B)

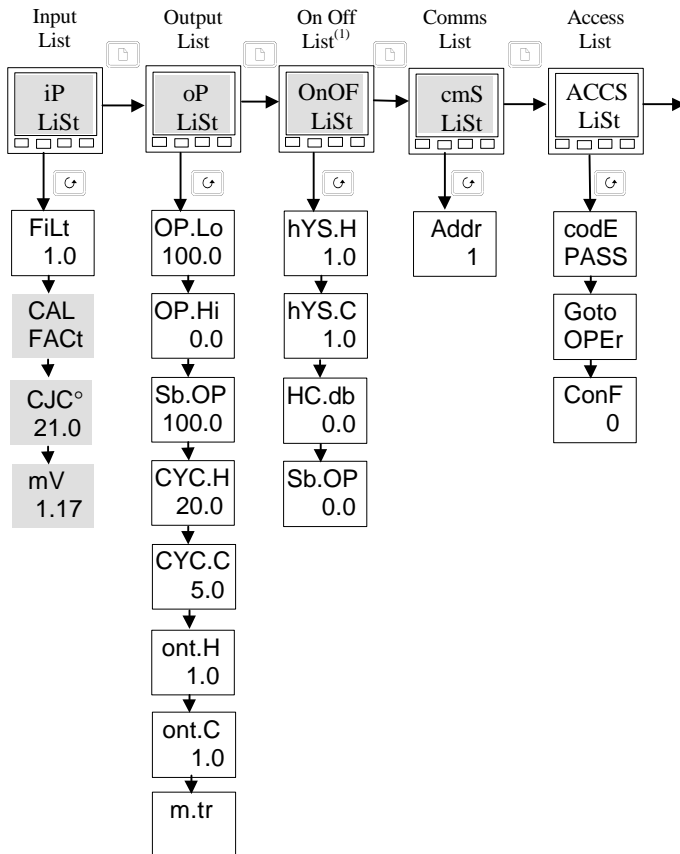

### Notes:

1. Either the PID list or the On/Off list will be present depending upon the type of control in use.
2. The last three characters depend upon the type of alarm configured.
3. **Beware!** Used for calibration.  
 The shaded boxes are normally hidden in Operator level. To see all the available parameters you must select Full level.

# MARATHON MONITORS INC.

---

## PARAMETER TABLES

Name	Parameter Description
------	-----------------------

Home list	
Home	Measured value and Setpoint
OP	% Output level
m - A	Auto/manual select
rEF	Reference number
Strt	Dwell timer control
tmr	Dwell time remaining
<p>+Additional parameters may appear in the Home display list if the 'promote' feature has been used (see <i>Edit Level</i>, Chapter 3).</p>	

AL	Alarm list
1 - - -	Alarm 1 setpoint value
2 - - -	Alarm 2 setpoint value
3 - - -	Alarm 3 setpoint value
4 - - -	Alarm 4 setpoint value
<p><i>In place of dashes, the last three characters indicate the alarm type as follows:</i></p>	
- FSH	Full scale high alarm
- FSL	Full scale low alarm
- dEv	Deviation band alarm
- dHi	Deviation high alarm
- dLo	Deviation low alarm
Lb t	Loop Break Time in seconds
Name	Parameter Description

Atun	Autotune list
tunE	Self-tune enable
Adc	Automatic Manual Reset Calculation Enable (PD only control)

Pid	PID list
Pb	Proportional Band (in display units)
ti	Integral Time in seconds
td	Derivative Time in seconds
rES	Manual Reset (%)
Hcb	Cutback High

# MARATHON MONITORS INC.

---

Lcb	Cutback Low
rEL.C	Relative Cool Gain (set 1)

SP	Setpoint list
SSEL	Select SP1 or SP2
SP 1	Setpoint one value
SP 2	Setpoint two value
SP1.L	Setpoint 1 low limit
SP1.H	Setpoint 1 high limit
SP2.L	Setpoint 2 low limit
SP2.H	Setpoint 2 high limit
DwEil	Dwell time (min)
Strt	Dwell time control
tmr	Dwell time remaining

iP	Input list
FiLt	Input filter time constant. 1.0 to 999.9 seconds
<i>The following two parameters are always present in Full access level</i>	
C.JC°	Cold junction temperature
mV	Millivolt inputs

Name	Parameter Description
<b>oP</b>	<b>Output list</b>
<i>If On/Off control has been configured the only parameters that will appear are 'ont.H' and 'ont.C'</i>	
OP.Lo	Low power limit (%)
OP.Hi	High power limit (%)
Sb.OP	Sensor Break Power (%)
CYC.H	Heat cycle time from 200mS to 600 seconds
CYC.C	Cool cycle time from 200mS to 600 seconds
ont.H	Heat output min. on time (secs)
ont.C	Cool output min. on time (secs)
M.tr	Motor travel time (secs)

OnOF	On/Off list
<i>This set of parameters appear if On/Off control has been configured</i>	
hYS.H	Heat hysteresis (in display units)
hYS.C	Cool hysteresis (in display units)

# MARATHON MONITORS INC.

---

HC.db	Heat/cool deadband (in display units)
Sb.OP	Sensor Break Power (%)

<b>cmS</b>	<b>Comms list</b>
Addr	Communications Address

<b>ACCS</b>	<b>Access List</b>
codE	Full and Edit level password
Goto	Goto level - OPEr, FuLL, Edit or conF
ConF	Configuration level password

## List header displays

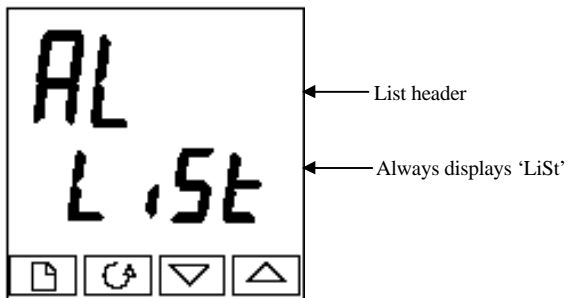
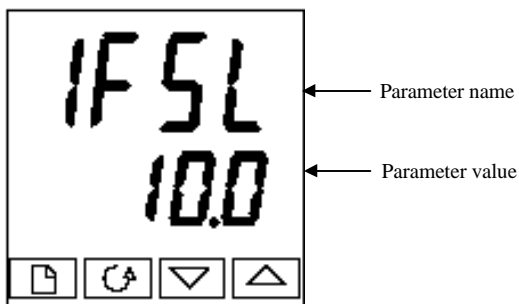

**Figure 2-5**

### Typical list header display

You can recognize a list header by the fact that it always shows 'LiSt' in the lower readout. The upper readout is the name of the list. In the above example, AL indicates that it is the Alarm list header. Listheader displays are read-only.



## Parameter displays



**Figure 2-6**

### Typical parameter display

Parameter displays show the controllers' current settings. The layout of parameter displays is always the same: the upper readout shows the parameter name and the lower readout it's value.

Alterable parameters can be changed using the  or  buttons. In the above example, the parameter mnemonic is 1FSL (indicating *Alarm 1, full scale low*), and the parameter value is 10.0.

# MARATHON MONITORS INC.

---

## ALARM MESSAGES

### Alarm annunciation

If the controller detects an alarm condition, it will flash a message in either the upper or lower readout of the Home display. A new alarm will be displayed as a double flash followed by a pause. Old (acknowledged) alarms will be displayed as a single flash followed by a pause. If there is more than one alarm condition, the display cycles through all the relevant alarm messages. Tables 2.1 and 2.2 list all of the possible alarm messages and their meaning.

### Alarm modes

Alarms will have been set up to operate in one of several modes, either:

- **Non-latching**, which means that the alarm will automatically clear when the alarm condition no longer exists.
- **Latching**, which means that the alarm message will continue to flash even if the alarm condition no longer exists. Latched alarms are cleared (*acknowledged*) by pressing either the Page or Scroll button.
- **Blocking**, which means that the alarm will only become active after it has first entered a safe state after powering up

### Alarm types

There are two kinds of alarm: **Process alarms** and **Diagnostic alarms**

#### Process alarms

These warn that there is a problem with the process that the controller is trying to control.

Alarm Display	What it means
-FSH*	Full Scale High alarm
-FSL*	Full Scale Low alarm
-dHi*	Deviation High alarm
-dLo*	Deviation Low alarm
-dEV*	Deviation Band alarm
End	Dwell Time

**Table 2-1**  
**Process alarms**

*\*In place of the dash, the first character will indicate the alarm number*

# MARATHON MONITORS INC.

---

## Diagnostic alarms

These indicate that a fault exists in either the controller or the connected devices.

Display shows	What it means	What to do about it
EE.Er	<i>Electrically Erasable Memory Error:</i> The value of an operator or configuration parameter has been corrupted.	This fault will automatically take you into configuration level. Check all of the configuration parameters before returning to operator level. Once in operator level, check all of the operator parameters before resuming normal operation. If the fault persists or occurs frequently, contact Marathon Monitors.
S.br	<i>Sensor Break:</i> Input sensor is unreliable or the input signal is out of range.	Check that the sensor is correctly connected.
L.br	<i>Loop Break:</i> The feedback loop is open circuit.	Check that the heating and cooling circuits are working properly.
HW.Er or no.io	<i>Hardware error</i> Indication that a module is of the wrong type, missing or faulty.	Check that the correct modules are fitted.

**Table 2-2a**  
**Diagnostic alarms**

## Diagnostic alarms continued

These indicate that a fault exists in either the controller or the connected devices.

Display shows	What it means	What to do about it
LLLL	<i>Out of range low reading.</i>	Check the value of the input.
HHHH	<i>Out of range high reading.</i>	Check the value of the input.
Err1	<i>Error 1: ROM self-test fail.</i>	Return the controller for repair.
Err2	<i>Error 2: RAM self-test fail.</i>	Return the controller for repair.
Err3	<i>Error 3: Watchdog fail.</i>	Return the controller for repair.
Err4	<i>Error 4: Keyboard failure</i>	Switch the power off and then on without touching

# MARATHON MONITORS INC.

---

	Stuck button, or a button was pressed during power up.	any of the controller buttons.
Err5	<i>Error 5: Input circuit failure.</i>	Return the controller for repair.
Pwr.F	<i>Power failure.</i> The line voltage is too low.	Check that the supply to the controller is within the rated limits.

**Table 2-2b**  
**Diagnostic alarms**



## Chapter 3 TIMER FUNCTION

### DWELL TIMER STATE DIAGRAM

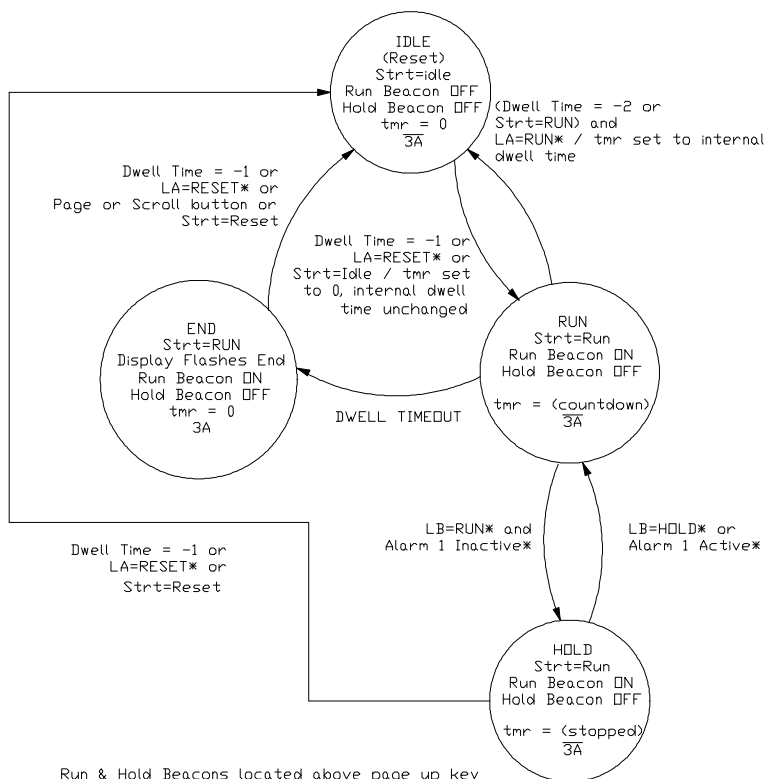

Run & Hold Beacons located above page up key  
 Dwell Time = -1 same as Strt = Idle  
 Dwell Time = -2 same as Strt = Run

\* If configured to be part of timer function

Legend:

- 3A Event relay on terminals 3A, B & C configured as Dwell End energized
- 3A Event relay configured as Dwell End de-energized
- Dwell Time MMI protocol Dwell Time write parameter "I" or "J"
- LA digital Input 1, configured as Dwell Timer Run/Reset
- LB digital 2, configured as Dwell Timer Run/Hold
- Strt Scroll list parameter used to activate a Dwell Run or Reset
- tmr Dwell time remaining scroll list parameter

# MARATHON MONITORS INC.

---

The 10pro-e contains a dwell timer which can be used independent of or dependent on the process. To use the dwell timer it must first be enabled in the instrument configuration list. When the dwell timer is enabled, Alarm 1 will always effect the timer and the 10Pro-e will respond to two communications addresses. Alarm 1 being active (alarm state) will always place the dwell timer in hold whether or not Alarm 1 is assigned to a contact. The communications port will respond to address+1 for the dwell timer in temperature communications mode but not the block transfer mode.

The normal hardware assignments for use with the timer are: contact 3A to the 'End' function, digital input LA to the 'rSET' function, and digital input LB to the 'HOLD' function. Although other assignments could be made, these are the setups used in the Dwell Timer State Diagram and descriptions in this manual. Only the assignments required for the specific application should be made. If the digital inputs are not required then do not assign them to the 'rSET', 'HOLD', or 'Stby' modes

The dwell timer has four states. The IDLE (reset) state is the inactive condition. The RUN state is the active state when the timer is counting down. The HOLD state is when counting is paused due to either digital input LB = hold or alarm 1 active. The END state is when the timer has timed-out (reached 0) and has not been acknowledged. Contact 3A will be active during the END state.

The simplest form of operation for the dwell timer is without digital inputs assigned and Alarm 1 off. To start the timer, enter the time into dwell under the SP list then change the strt function to run. The run beacon will light and the timer will count down. When the timer reaches zero, end will flash in the lower display and contact 3A will activate. The timer is acknowledged by pressing either the page or scroll buttons. the timer can be restarted for the same dwell time by setting the strt function to run.

To make the timer dependent on the process, set Alarm 1 to the desired dependency. For example, a guaranteed soak timer is achieved by setting Alarm 1 as a deviation band alarm. The dwell timer is started as before; however, if the process should wander outside of the deviation band then the Alarm 1 state will flash on the lower display and the dwell timer will hold.

# MARATHON MONITORS INC.

---

The following is a summary of ways to change the state of the dwell timer. These assume the standard setups are in effect.

Timer will start if:

1. Strt function = run
2. Digital input LA = Run
3. Communications sends a -2 for dwell setpoint

Timer will hold if:

1. Digital input LB = Hold
2. Alarm 1 is active (alarm state)

Timer will reset to IDLE without activating End if:

1. Strt function = idle
2. Digital input LA = reset
3. Communications sends a -1 for the dwell setpoint

Timer goes to End state if:

1. Timer count reaches 0

Timer returns to IDLE state from End when:

1. Operator press Scroll or Page button
2. Digital input LA = reset.
3. Communications sends a -1 for the dwell setpoint
4. Strt function = idle

# MARATHON MONITORS INC.

---



## Chapter 4 ACCESS LEVELS

This chapter describes the different levels of access to the operating parameters within the controller.

There are three topics:

- THE DIFFERENT ACCESS LEVELS
- SELECTING AN ACCESS LEVEL
- EDIT LEVEL

### THE DIFFERENT ACCESS LEVELS

There are three access levels:

- **Operator level**, which you will normally use to operate the controller
- **Full level**, which is used to commission the controller and the process being controlled
- **Edit level**, which is used to set up the parameters that you want an operator to be able to see and adjust when in Operator level

Access level	Display shows	What you can do	Password Protection
Operator	OPER	In this level operators can view and adjust the value of parameters defined in Edit level (see below).	No
Full	FuLL	In this level all the parameters relevant to a particular configuration are visible. All alterable parameters may be adjusted.	Yes
Edit	Edit	In this level you can set which parameters an operator in Operator level is able to view and adjust. You can hide or reveal complete lists and individual parameters within each list, and you can make parameters read-only or alterable. (See <i>Edit level</i> at the end of the chapter).	Yes

**Figure 3-1**  
**Access levels**



## Access list header

### Access List Header

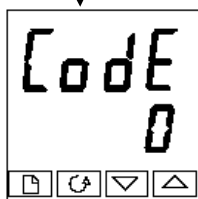

Press  until you reach the access list header 'ACCS'.



*Press the Scroll button*

## Password entry

The password is entered from the 'Code' display.

Enter the password using the  or  buttons. Once the correct password has been entered, there is a two second delay after which the lower readout will change to show 'PASS' indicating that access is now unlocked.

The pass number is set to '1' when the controller is shipped from the factory.

*Note:* A special case exists if the password has been set to '0'. In this case access will be permanently unlocked and the lower readout will always show 'PASS'

*Press the Scroll button to proceed to the 'Goto' display.*

**(If an *incorrect* password has been entered and the controller is still 'locked' then pressing *Scroll* at this point will simply return you to the access list header.)**



# MARATHON MONITORS INC.

---



## Level selection

The 'Goto' display allows you to select the required access level.

Use  and  to select from the following display codes:

- OPEr: Operator level
- FuLL: Full level
- Edit: Edit level
- conF: Configuration level



*Press the Scroll button*

If you selected either 'OPEr, FuLL or Edit level you will be returned to the 'ACC5 list header in the level that you chose

# MARATHON MONITORS INC.

---

## Returning to Operator Level

To return to operator level from either 'FuLL' or 'Edit' level, repeat entry of the password and select 'OPER' on the 'Goto' display.

In 'Edit' level the controller will automatically return to operator level if no button is pressed for 45 seconds.

## EDIT LEVEL



Edit level is used to set which parameters you can see and adjust in Operator level. It also gives access to the 'Promote' feature which allows you to select and add ('Promote') up to twelve parameters into the Home display list, thereby giving simple access to commonly used parameters.

### Setting operator access to a parameter

First you must select Edit level, as shown on the previous page.

Once in Edit level you select a list or a parameter within a list in the same way as you would in Operator or Full level—that is to say, you move from list header to list header by pressing the Page button, and from parameter to parameter within each list using the Scroll button.

**However, in Edit level what is displayed is not the value of a selected parameter but a code representing the parameter's availability in Operator level.**

When you have selected the required parameter, use the  and  buttons to set its availability in operator level.

There are four codes:

- Altr** Makes a parameter alterable in Operator level
- Pro** Promotes a parameter into the Home display list
- REAd** Makes a parameter or list header read-only (*it can be viewed but not altered*)
- Hide** Hides a parameter or list header

For example:



The parameter selected is the sepoint for Alarm 2 - Full Scale Low

It will be alterable in Operator level

## **Hiding or revealing a complete list**

To hide a complete list of parameters, all you have to do is hide the list header. If a list header is selected only two selections are available: REAd and HidE.

(It is not possible to hide the 'ACCS' list which will always display the code: 'LiSt'.)

## **Promoting a parameter**

Scroll through the lists to the required parameter and choose the 'Pro' code. The parameter is then automatically added(promoted) into the Home display list (the parameter will also be accessible as normal from the standard lists. A maximum of twelve parameters can be promoted. Promoted parameters are automatically 'alterable'.

# MARATHON MONITORS INC.

---



## Chapter 5 TUNING

Before tuning please read Chapter 2, *Operation*, to learn how to select and change a parameter.

This chapter has three main topics:

- WHAT IS TUNING?
- AUTOMATIC TUNING
- MANUAL TUNING

### WHAT IS TUNING?

In tuning you match the characteristics of the controller to that of the process being controlled in order to obtain good control. Good control means:

- Stable 'straight-line' control of the temperature at setpoint without fluctuation
- No overshoot or undershoot of the temperature setpoint
- Quick response to deviations from the setpoint caused by external disturbances, thereby restoring the temperature rapidly to the setpoint value

Tuning involves calculating and setting the value of the parameters listed in Table 4-1. These parameters appear in the PID list.

Parameter	Code	Meaning or Function
Proportional band	Pb	The bandwidth in display units over which the output power is proportioned between minimum and maximum.
Integral time	ti	Determines the time taken by the controller to remove steady-state error signals.
Derivative time	td	Determines how strongly the controller will react to the rate-of-change of the measured value.
Low cutback	Lcb	The number of display units below setpoint at which the controller will cutback the output power in order to prevent overshoot on heat up.
High Cutback	Hcb	The number of display units above setpoint at which the controller will increase the output power in order to prevent undershoot on cool down.
Relative cool gain	rEL.C	Only present if cooling has been configured. Sets the cooling proportional band by dividing the Pb value by the rEL value.

### TUNING PARAMETERS

---

# MARATHON MONITORS INC.

---

## AUTOMATIC TUNING

This method automatically determines the value of the parameters listed in Table 4-1 on the previous page.

The 10PRO-e uses a 'one-shot' tuner which works by switching the output on and off to induce an oscillation in the measured value. From the amplitude and period of the oscillation, it calculates the tuning parameter values.

If the process cannot tolerate full heating or cooling being applied during tuning, then the level of heating or cooling can be restricted by setting the heating and cooling power limits in the Output list. However, the measured value *must* oscillate to some degree for the tuner to be able to calculate values.

A One-shot Tune can be performed at any time but normally it is performed only once during the initial commissioning of the process. However, if the process under control subsequently becomes unstable (because its characteristics have changed), you can re-tune again for the new conditions.

It is best to start tuning with the process at ambient temperature. This allows the tuner to calculate more accurately the low cutback and high cutback values that restrict the amount of overshoot or undershoot.

**Note:** If valve positioning control mode is selected the correct motor travel time **must be** entered into parameter m.tr in the output list or **erratic control will result**.

### How to tune

1. Set the setpoint to the value at which you will normally operate the process.
2. In the 'Atun' list, select 'tunE' and set it to 'on.'
3. Press the Page and Scroll buttons together to return to the Home display. The display will flash 'tunE' to indicate that tuning is in progress.
4. The controller will induce an oscillation in the temperature by turning the heating on and then off. The first cycle will not complete until the measured value has reached the required setpoint.
5. After two cycles of oscillation the tuning will be completed and the tuner will switch itself off.
6. The controller will then calculate the tuning parameters listed in Table 4-1 and will resume normal control action.

If you want 'Proportional only' or 'PD' or 'PI' control, you should set the 'ti' or 'td' parameters to OFF before commencing the tuning cycle. The tuner will leave them off and will not calculate a value for them.

## Typical automatic tuning cycle

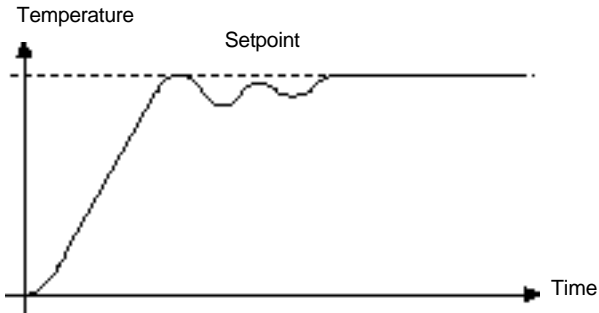

## Calculation of the cutback values

*Low cutback* and *High cutback* are values that restrict the amount of overshoot or undershoot that occurs during large step changes in temperature (for example, under start-up conditions). If either low cutback or high cutback is set to 'AUTO' the values will be fixed at three times the proportional band, and will not be changed during automatic tuning.

# MARATHON MONITORS INC.

---

## MANUAL TUNING

If for any reason automatic tuning gives unsatisfactory results, you can tune the controller manually. There are a number of standard methods for manual tuning. The one described here is the Ziegler-Nichols method.

With the process at its normal running temperature:

1. Set the Integral Time 'ti' and the Derivative Time 'td' to OFF.
2. Set High Cutback and Low Cutback, 'Hcb' and 'Lcb', to 'Auto.'
3. Ignore the fact that the temperature may not settle precisely at the setpoint.
4. If the temperature is stable, reduce the proportional band 'Pb' so that the temperature just starts to oscillate. If the temperature is already oscillating, increase the proportional band until it just stops oscillating. Allow enough time between each adjustment for the loop to stabilize. Make a note of the proportional band value 'B' and the period of oscillation 'T'.
5. Set the Pb, ti, td parameter values according to the calculations given in Table 4-2.

Type of control	Proportional band 'Pb'	Integral time 'ti'	Derivative time 'td'
Proportional only	2xB	OFF	OFF
P + I control	2.2xB	0.8xT	OFF
P + I + D control	1.7xB	0.5xT	0.12xT

Tuning Values

# MARATHON MONITORS INC.

---

## Setting the cutback values

The above procedure sets up the parameters for optimum steady state control. If unacceptable levels of overshoot or undershoot occur during start-up or for large step changes in temperature, then manually set the cutback parameters  $L_{cb}$  and  $H_{cb}$ .

### *Proceed as follows:*

1. Set the low and high cutback values to three proportional bandwidths (that is to say,  $L_{cb} = H_{cb} = 3 \times P_b$ ).
2. Note the level of overshoot or undershoot that occurs for large temperature changes (see the diagrams below).

In example (a) increase  $L_{cb}$  by the overshoot value. In example (b) reduce  $L_{cb}$  by the undershoot value.

### Example (a)

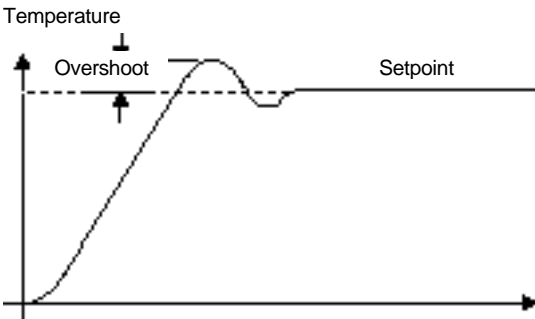

### Example (b)

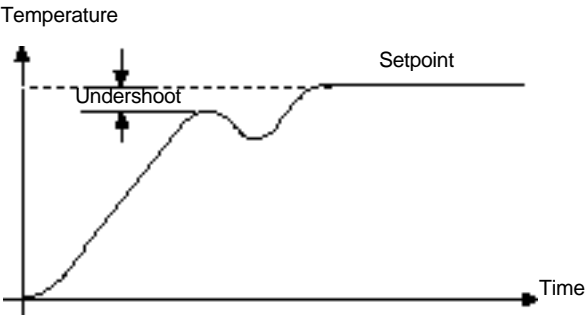

Where the temperature approaches setpoint from above, you can set  $H_{cb}$  in a similar manner.

## **Integrating action and manual reset**

In a full three-term controller (that is, a PID controller), the integral term 'ti' automatically removes steady state errors from the setpoint. If the controller is set up to work in two-term mode (that is, PD mode), the integral term will be set to 'OFF'. Under these conditions the measured value may not settle precisely at setpoint. When the integral term is set to OFF the parameter *manual reset* (code rES) appears in the PID list. This parameter represents the value of the power output that will be delivered when the error is zero. You must set this value manually in order to remove the steady state error.

## **Automatic droop compensation (Adc)**

The steady state error from the setpoint which occurs when the integral term is set to 'OFF' is sometimes referred to as 'droop'. Adc automatically calculates the manual reset value in order to remove this droop. To use this facility, you must first allow the temperature to stabilize. Then, in the autotune parameter list, you must set Adc to 'CALC'. The controller will then calculate a new value for manual reset, and switch Adc to 'mAn'.

Adc can be repeated as often as you require, but between each adjustment you must allow time for the temperature to stabilize.



## Chapter 6 CONFIGURATION

This chapter consists of five topics:

- SELECTING CONFIGURATION LEVEL
- LEAVING CONFIGURATION LEVEL
- SELECTING A CONFIGURATION PARAMETER
- THE CONFIGURATION NAVIGATION DIAGRAM
- THE CONFIGURATION PARAMETER TABLES

In configuration level, you set up the fundamental characteristics of the controller. These are:

- The type of control (e.g. PID or On/Off)
- The Input type and range
- The Alarm functions
- The logic input functions
- The Output functions
- The Communications configuration
- Calibration
- The Passwords

---



### WARNING

**Configuration is protected by a password and should only be carried out by a qualified person authorised to do so. Incorrect configuration could result in damage to the process being controlled and/or personal injury. It is the responsibility of the person commissioning the process to ensure that the configuration is correct.**

---

## SELECTING CONFIGURATION LEVEL

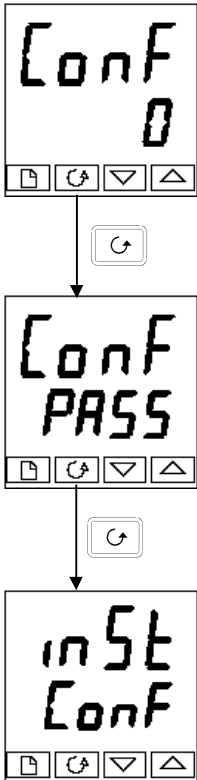

There are two alternative methods of selecting Configuration level:

- If you have already powered up the controller, then follow the access instructions given in Chapter 3: *Access levels*.
- Alternatively press  and  together when powering up the controller. This will take you straight to the 'ConF' password entry display.



### Password entry

When the 'ConF' display appears, you must enter the Configuration password in order to gain access to Configuration level.

Enter the password using the  or  buttons.

The configuration password is set to '2' when the controller is shipped from the factory.

Once the correct password has been entered, there is a two second delay after which the lower readout will change to 'PASS' indicating that access is now unlocked.

*Note:* A special case exists if the password has been set to '0'. In this situation access will be permanently unlocked and the lower readout will always show 'PASS.'

*Press the Scroll button to enter configuration level*

This is the first display in configuration level.



(If an incorrect password has been entered and the controller is still 'locked' then pressing *Scroll* at this point will take you to the 'Exit' display with 'no' in the lower readout. Simply press *Scroll* to return to the 'ConF' display).

# MARATHON MONITORS INC.



---

## LEAVING CONFIGURATION LEVEL

To leave Configuration level and return to Operator level, Press  until the 'Exit' display appears.

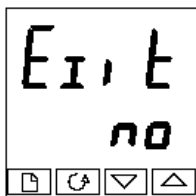
Alternatively pressing  and  together will take you straight to the 'Exit display'.







Use  or  to select 'YES'. After a two-second delay, the display will flash and revert to the Home display in Operator level

## SELECTING A CONFIGURATION PARAMETER

The configuration parameters are arranged in lists as shown in the navigation diagram in Figure 5.1a and 5.1b. Each box in the diagram depicts the display for a particular list header or parameter.

**To select a particular parameter,** you must first select the list in which the parameter appears.

**You step through the list headers** by pressing the Page button . You can recognize a list header by the fact that it always shows 'ConF' in the lower readout. The upper readout is the name of the list.

Having selected a particular list header, **You step through the parameters** within a particular list by pressing the Scroll button . The upper readout shows the name of the parameter and the lower readout its value. The value of a parameter is changed by using the  or  buttons. For a definition of each parameter, see the configuration parameter tables at the end of this chapter.

When you reach the end of the list you will return to the list header. From within a list you can return to the list header at any time by pressing the Page button .

## Parameter availability

# MARATHON MONITORS INC.

---

The navigation diagram shows all the lists headers and parameters that potentially can be present in the controller. In practice, those actually present will vary according to the particular configuration choices you make.

# MARATHON MONITORS INC.

## CONFIGURATION NAVIGATION DIAGRAM (PART A)

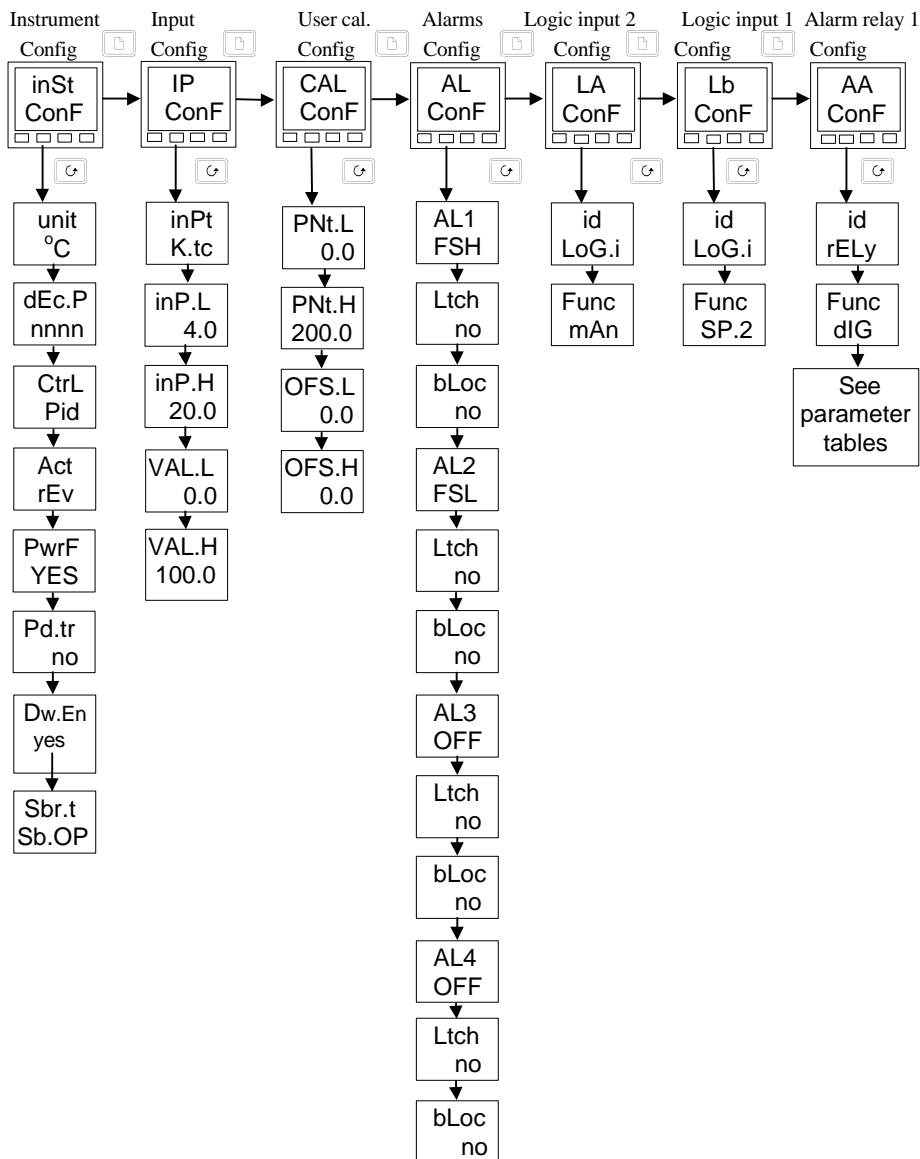

Fig 5.1a Configuration Navigation Diagram (Part A)

# MARATHON MONITORS INC.

## CONFIGURATION NAVIGATION DIAGRAM (PART B)

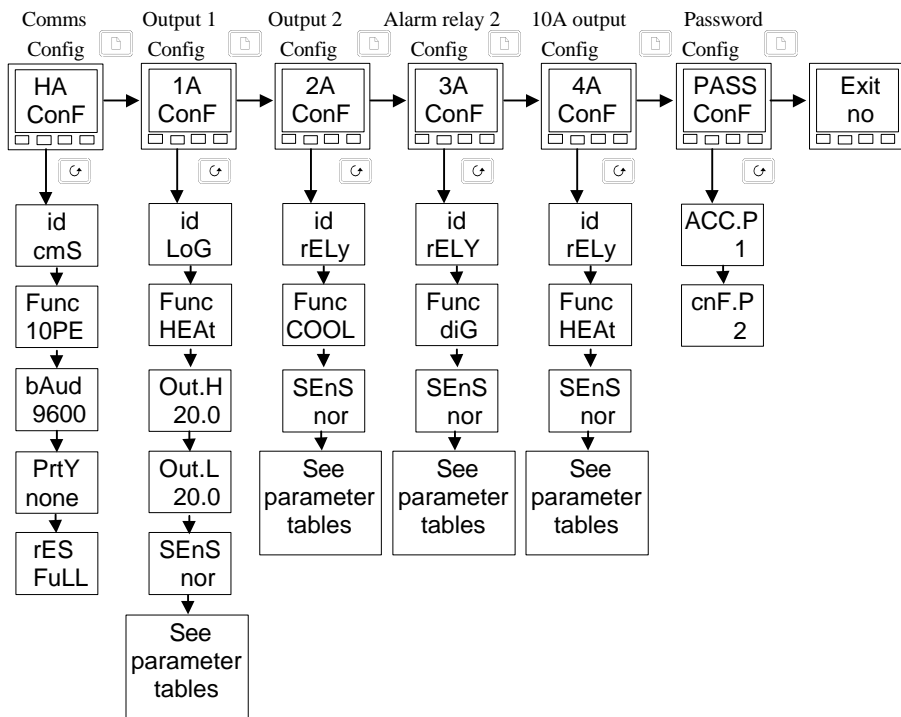

Fig 5.1b Configuration Navigation Diagram (Part B)

# MARATHON MONITORS INC.

## CONFIGURATION PARAMETER TABLES

Name	Parameter description	Values	Meaning
<b>inSt</b>	<b>Instrument configuration</b>		
unit	Instrument units	°C °F °K nonE	Centigrade Fahrenheit Kelvin Display units will be blanked
dEc.P	Decimal places in the displayed value	nnnn nnn.n nn.nn	None One Two
Ctrl	Control type	On.OF Pid, vP	On/off PID control, valve positioning
Act	Control action	rEv dir	Reverse Direct or VP acting
PwrF	Power feedback	On OFF	Power feedback is on Power feedback is off
Pd.tr	Bumpless Manual/Auto transfer when using PD control	HoLd trAc	Non-bumpless transfer Bumpless transfer
dw.En	Dwell	Yes No	+
Sbr.t	Sensor break output	Sb.OP HoLd	Go to pre-set value Freeze output

Name	Parameter description	Values	Meaning
<b>iP</b>	<b>Input configuration</b>		
inPt	Input type	J.tc K.tc r.tc b.tc n.tc t.tc S.tc rtd C.tc  mV voLt	J thermocouple K thermocouple R thermocouple (Pt/Pt13%Rh) B thermocouple (Pt30%Rh/Pt6%Rh) N thermocouple T thermocouple S thermocouple (Pt/Pt10%Rh) 100Ω platinum resistance thermo. This is the custom downloaded input type. The default is C thermocouple. If not, the name of the downloaded custom input will be displayed. Linear millivolt Linear voltage
<i>The following parameters will appear if a linear input is chosen.</i>			
inP.L	Input value low		Linear input low value
inP.H	Input value high		Linear input high value
VAL.L	Display reading low		Display reading corresponding to 'inp.L'
VAL.H	Display reading high		Display reading corresponding to 'inp.H'

\*If User calibration is enabled, then the User calibration parameters will appear in the Input list  
of Operator Full access level.

# MARATHON MONITORS INC.

Name	Parameter description	Values
------	-----------------------	--------



AL	Alarm configuration	Values
AL1	Alarm 1 Type	Select table A
Ltch	Alarm 1 Latching	no/YES
bLoc	Alarm 1 Blocking <sup>(1)</sup>	no/YES
AL2	Alarm 2 Type	Select table A
Ltch	Alarm 2 Latching	no/YES
bLoc	Alarm 2 Blocking <sup>(1)</sup>	no/YES
AL3	Alarm 3 Type	Select table A
Ltch	Alarm 3 Latching	no/YES
bLoc	Alarm 3 Blocking <sup>(1)</sup>	no/YES
AL4	Alarm 4 Type	Select table A
Ltch	Alarm 4 Latching	no/YES
bLoc	Alarm 4 Blocking <sup>(1)</sup>	no/YES
<b>Table A: Alarm types</b>		
OFF	No alarm	
FSH	Full scale high	
FSL	Full scale low	
dEv	Deviation band	
dHi	Deviation high	
dLo	Deviation low	

<sup>(1)</sup> Alarm blocking allows the alarm to become active only after it has first entered a safe state.

LA	Logic input 1 configuration	Functions	Action on contact closure
id	Identity of input	LoG.i	Logic input
Func	Function	nonE mAn rmt SP.2  ti H Ac.AL Hold rSET Stby	None Manual mode select Remote setpoint select Setpoint 2 or remote setpoint select Integral hold Acknowledge alarms Dwell timer hold Dwell timer reset Dwell timer standby

Lb	Logic input 2 configuration	Functions	Action on contact closure
As per Logic input 1			

# MARATHON MONITORS INC.

Name	Parameter description	Functions	Meaning
<b>AA</b>	<b>Alarm relay 1 configuration</b>	<b>Functions</b>	<b>Meaning</b>
id	Identity of output	rELy	Relay
Func	Function	noNE diG HEAt COOL	None Function set by diG.F Heating Cooling
diG.F	Digital output functions Any number of the functions listed can be combined onto the logic output. Use the  and  buttons to select a desired output function. After two seconds the display will blink and return to the 'no.CH' display. Use the arrows again to scroll through the function list. The previously selected function display will show two decimal points indicating that it has been added to the output.	no.CH Clr 1 - - 2 - - 3 - - 4 - - Sbr Lbr LdF mAN SPAn End	No change Clear all existing functions Alarm 1* Alarm 2* Alarm 3* Alarm 4* Sensor break Loop break PDSIO Load failure Manual mode PV out of range Dwell Time
SEnS	Sense of output	nor inv	Normal ( <i>heat and cool outputs</i> ) Inverted ( <i>alarms - de-energizes in the alarm state</i> )

\*In place of the dashes, the last three characters indicate the alarm type.



If an alarm is not configured the displayed name will differ: e.g. for the first alarm 'AL 1' will be shown.

# MARATHON MONITORS INC.

---

HA	Comms module config	Functions	Meaning
id	Identity of the option installed	cmS	EIA 485 comms module
Func	Function <i>The following parameters will appear if the EIA-485 option is installed</i>	10PE nonE	MMI protocol None
<i>The following parameters will appear if the function chosen is MMI protocol.</i>			
bAud	Baud Rate	1200, 2400, 4800, 9600, 19.20(19,200)	
PrtY	Comms Parity	nonE EvEn Odd	No parity Even parity Odd parity
rESn	Resolution	Int full	Integer resolution Full resolution

# MARATHON MONITORS INC.

Name	Parameter description	Functions	Meaning
<b>1A</b>	<b>Output 1 configuration</b>	<b>Functions</b>	<b>Meaning</b>
id	Identity of module installed	rELY dC.OP LoG SSr	Relay output DC output Logic or PDSIO output Triac output
Func	Function	nonE	
		diG HEAt COOL	Function set by diG.F Heating output (VP Open) Cooling output
<i>The following parameters appear if a DC module is installed.</i>			
Out.L	DC output minimum	0mA to 'Out.H'	
Out.H	DC output maximum	'Out.L.' to 20mA	
<i>The following parameters appear if 'diG' is chosen as the function</i>			
diG.F	Digital output functions Any number of the functions listed can be combined onto the logic output. Use the  and  buttons to select a desired output function. After two seconds the display will blink and return to the 'no.CH' display. Use the arrows again to scroll through the function list. The previously selected function display will show two decimal points indicating that it has been added to the output.	no.CH Clr 1 - - - 2 - - - 3 - - - 4 - - - S.br L.br  mAN SPAn End	No change Clear all existing functions Alarm 1* Alarm 2* Alarm 3* Alarm 4* Sensor break Loop break  Manual mode PV out of range Dwell Time
SEnS	Sense of output	nor inv	Normal ( <i>heat and cool outputs</i> ) Inverted ( <i>alarms - de-energizes in the alarm state</i> )

\*In place of the dashes, the last three characters indicate the alarm type.



If an alarm is not configured the displayed name will differ: e.g. for the first alarm 'AL 1' will be shown.

# MARATHON MONITORS INC.

Name	Parameter description	Functions	Meaning
------	-----------------------	-----------	---------

2A	Output 2 configuration	Functions	Meaning
id	Identity of module installed	rELY LoG SSr	Relay output Logic output Triac output
Func	Function	nonE	
		diG HEAt COOL	Function set by diG.F Heating output Cooling output (VP Close)

*The following parameters appear if 'diG' is chosen as the function*

diG.F	Digital output functions Any number of the functions listed can be combined onto the logic output. Use the  and  buttons to select a desired output function. After two seconds the display will blink and return to the 'no.CH' display. Use the arrows again to scroll through the function list. The previously selected function display will show two decimal points indicating that it has been added to the output.	no.CH Clr 1 - - - 2 - - - 3 - - - 4 - - - S.br L.br mAN SPAn End	No change Clear all existing functions Alarm 1* Alarm 2* Alarm 3* Alarm 4* Sensor break Loop break Manual mode PV out of range Dwell Time
SEnS	Sense of output	nor inv	Normal ( <i>heat and cool outputs</i> ) Inverted ( <i>alarms - de-energizes in the alarm state</i> )

\*In place of the dashes, the last three characters indicate the alarm type. If an alarm is not configured the displayed name will differ: e.g. for the first alarm 'AL 1' will be shown.

3A	Alarm 2 relay configuration	Functions	Action on contact closure
As per Alarm 1 'AA' relay configuration or soak timer			

4A	10Amp heating output	Functions	Action on contact closure
As per Alarm 1 'AA' relay configuration			

PASS	Password list		
ACC.P	FuLL or Edit level password		
cnF.P	Configuration level Password		

Exit	Exit configuration	no/YES	



## Chapter 7 USER CALIBRATION

This chapter has four topics:

- WHAT IS THE PURPOSE OF USER CALIBRATION?
- USER CALIBRATION ENABLE
- SINGLE POINT CALIBRATION
- TWO POINT CALIBRATION
- CALIBRATION POINTS AND CALIBRATION OFFSETS

To understand how to select and change parameters in this chapter you will need to have read Chapter 2 - *Operation*, Chapter 4- *Access Levels* and Chapter 6 - *Configuration*.

### WHAT IS THE PURPOSE OF USER CALIBRATION?

The basic calibration of the controller is highly stable and set for life. User calibration allows you to offset the 'permanent' factory calibration to either:

1. Calibrate the controller to the your reference standards
2. Match the calibration of the controller to that of a particular transducer or sensor input
3. Calibrate the controller to suit the characteristics of a particular installation.
4. Remove long term drift in the factory set calibration.

User calibration works by introducing zero and span offsets onto the factory set calibration.

# MARATHON MONITORS INC.

## USER CALIBRATION ENABLE

The User calibration facility must first be enabled in configuration level by setting the parameter 'Adj' in the CAL conf list to 'YES'. This will make the User calibration parameters appear in Operator 'Full' level (note: if the 10 Pro-e firmware number is B1.31 or less the user calibration does not work).

Select configuration level as shown in Chapter 5, Configuration

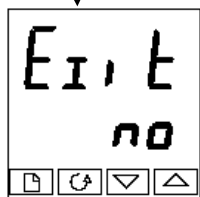
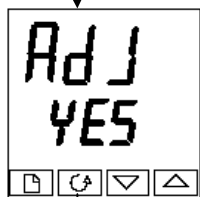

The User calibration configuration List



Press  until you reach the 'CAL' conf list

Press the Scroll button until you reach



### User calibration enable

Use  or  to select:

- **YES:** Calibration enable
- **no:** Calibration disabled

Press  and  together to go to the Exit display

### Exit configuration

Use  or  to select 'YES' and return to Operator level

# MARATHON MONITORS INC.

## Single point calibration

A single point calibration is used to apply a fixed offset over the full display range of the controller.

To calibrate at a single point proceed as follows:

1. Connect the input of the controller to the source device to which you wish to calibrate.
2. Set the source to the desired calibration value
3. The controller will display the current measurement of the value
4. If the displayed value is correct then the controller is correctly calibrated and no further action is necessary. If it is incorrect then follow the steps shown below

Select 'Full' Access level as describe in Chapter 3





## Input list header

Press  until you reach the input list header.

*Press Scroll until you reach the 'CAL' display*

## Calibration type

Use  or  to select either 'FAcT' or 'USER'.

Selecting 'FAcT' will reinstate the factory calibration and hide the following User calibration parameters.

Selecting 'USER' will reinstate any previously set User calibration and make available the next set of parameters.

*Press the Scroll button*

## Calibrate low point?

Use  or  to select 'YES'

Selecting 'no' will hide the next parameter

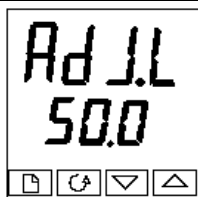

*Press the Scroll button*



## Adjust the low point calibration



The controller will display the current measured input value in the lower readout.

Set the input to the desired calibration value and allow it to stabilise. You can calibrate at any point over the entire display range

Use  or  to adjust the reading to the correct value.

After a two second delay the display will blink and the reading will change to the new, calibrated value.

The calibration is now complete. You can return to the factory calibration at any time by select 'FACT' in the CAL display shown earlier.

Press  and  together to return to the Home display

To protect the calibration against unauthorised adjustment return to Operator level and make sure that the calibration parameters are hidden. Parameters are hidden using the 'Edit' facility describe in Chapter 3.

## TWO POINT CALIBRATION

The previous section described how to perform a single point calibration which applies a fixed offset over the full display range of the controller. A two-point calibration is used to calibrate the controller at two points and apply a straight line between them. Any readings above or below the two calibration points will be an extension of this straight line. For this reason it is best to calibrate with the two points as far apart as possible.

Proceed as follows:



1. Decide upon the low and high points at which you wish to calibrate.
2. Perform a single point calibration at the low calibration point in the manner describe in the previous section
3. After adjusting the low calibration point 'AdJ.L' continue to the high calibration point by pressing the Scroll button to obtain the display shown below

# MARATHON MONITORS INC.

---



## Calibrate high point?



Use  or  to select 'YES'  
Selecting 'no' will hide the next parameter

*Press the Scroll button*



## Adjust the high point calibration

The controller will display the current measured input value in the lower readout.

Set the input to the desired high calibration value and allow it to stabilise.

Use  or  to adjust the reading to the correct value.  
After a two second delay the display will blink and the reading will change to the new, calibrated value.

The calibration is now complete. You can return to the factory calibration at any time by select 'FACT' in the CAL display shown earlier.

Press  and  together to return to the Home display

# MARATHON MONITORS INC.

---

To protect the calibration against unauthorised adjustment return to Operator level and make sure that the calibration parameters are hidden. Parameters are hidden using the 'Edit' facility describe in Chapter 3.

## CALIBRATION POINTS AND CALIBRATION OFFSETS

If you wish to see the points at which the User calibration was performed and the value of the offsets introduced these are shown in Configuration, in the input list. The parameters are:

Name	Parameter description	Meaning
Pnt.L	User low calibration point	This is the value (in display units) at which a User last performed an 'AdJ.L' (adjust low calibration).
Pnt.H	User high calibration point	This is the value (in display units) at which a User last performed an 'AdJ.H' (adjust high calibration).
OFS.L	Low point calibration offset	Offset, in display units, at the user low calibration point 'Pnt.L'
OFS.H	High point calibration offset	Offset, in display units, at the user high calibration point 'Pnt.H'.